



# PROTIUM-3000 OC

FUEL CELL SYSTEM

**USER GUIDE V1.0-1.6**



# SAFETY, HANDLING & SUPPORT

**WARNING:** *Read all the safety information below before using PROTIUM-3000 OC. Failure to follow these safety instructions could result in fire, electric shock, or other injuries, or damage to PROTIUM-3000 OC Fuel Cell System (PROTIUM-3000 OC) or other property.*

**Handling** Handle PROTIUM-3000 OC with care. It is made of thin sheet metal, graphite, and plastic and has sensitive electrochemical membrane and components inside. PROTIUM-3000 OC is not designed for extreme conditions, rough handling, vibration, shock or drop. Keep PROTIUM-3000 OC away from heat, flame, strong sunlight, water, dust, soil or mud. Do not use a damaged PROTIUM-3000 OC.

**Repairing** PROTIUM-3000 OC is assembled under high compression. Do not disassemble or tamper with PROTIUM-3000 OC. Do not troubleshoot, repair or replace any component by yourself.

**Hydrogen** Use only high purity (99.999%) dry Hydrogen gas with PROTIUM-3000 OC. Hydrogen is a colorless, odorless and highly flammable gas. It is non-toxic but can cause asphyxiation. Follow all local rules and regulations for safe handling, storage and usage of Hydrogen gas. Do not smoke when operating PROTIUM-3000 OC.

**Ventilation** Operate PROTIUM-3000 OC in a well ventilated environment. Fresh air intake for the fuel cell oxidant blower, cooling air entry from the front of the protective mask, and hot air exit from the cooling fans shall not be obstructed or restricted.

**Purging** PROTIUM-3000 OC periodically flushes its anode during operation, releasing Hydrogen gas and water from the Hydrogen gas outlet. Do not block the Hydrogen gas outlet. Do not bring flame or electric spark close to the Hydrogen gas outlet. It is advisable to attach a longer gas tubing to the Hydrogen gas outlet connector and safely guide the purge exhaust far away from the fuel cell.

**CAUTION:** *Always put the Hydrogen gas outlet tubing behind the cooling fan and never in front of the fuel cell stack. Purged Hydrogen mixed with air intake into the fuel cell's cathode channels may cause fire and irreversible damage to the fuel cell.*

**Connectors, ports and buttons** Never force a connector into a port or apply excessive pressure to a button. If the connector and port do not join with reasonable ease, they probably do not match. Check for obstructions and ensure that the connector matches the correct port.

**Disposal and recycling** As PROTIUM-3000 OC contains electronic components, it must be disposed of separately from household waste. When PROTIUM-3000 OC reaches its end of life, follow local laws and regulations for proper disposal and recycling options.

**High-consequence activities** PROTIUM-3000 OC is a customized system with pending safety tests and certifications. It is not intended for use where the failure of the system could lead to death, personal injury or severe environmental damage.

**Disclaimer** Every effort has been made to ensure that the information in this manual is accurate. This manual serves to adequately recommend safe operating procedures, but shall not be treated as comprehensive. Do not use PROTIUM-3000 OC in any other way than the one recommended in this manual. Spectronik reserves the right to change system specifications, appearance or discontinue the product at any time.

**Warranty** Spectronik warrants the included hardware product and accessories against defects in materials and workmanship for the first 30 days after delivery. Spectronik does not warrant against normal wear and tear, nor damage caused by accident or abuse.

*To obtain service, contact [hello@spectronik.com](mailto:hello@spectronik.com)*

# 1 OVERVIEW

## 1.1 PROTIUM-3000 OC FUEL CELL

Back View

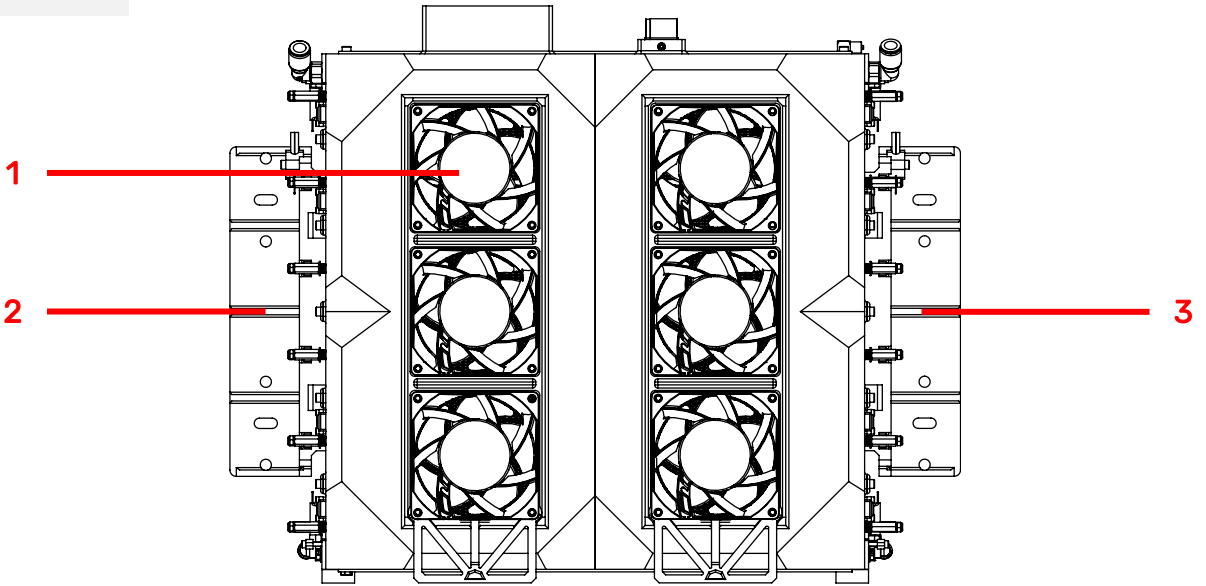

Front View

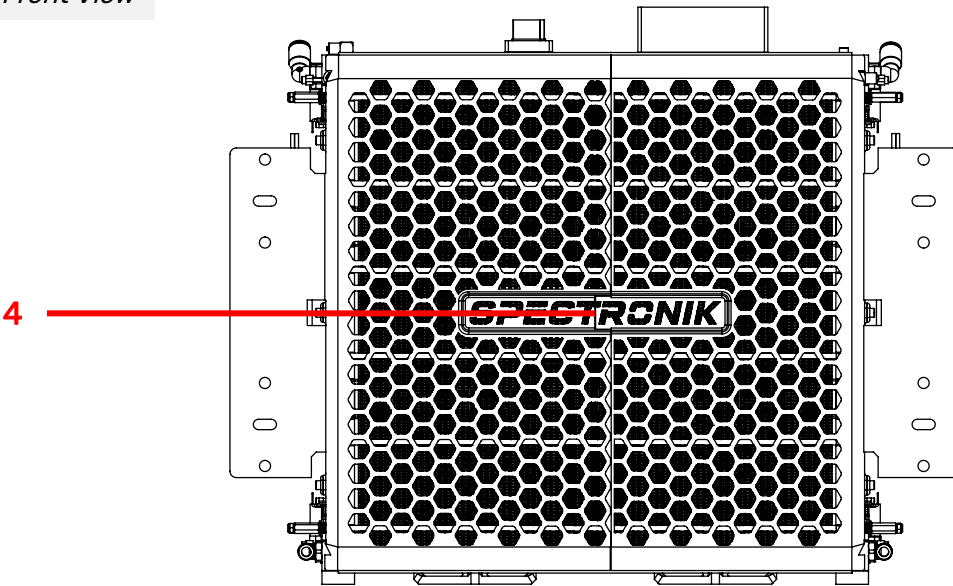

### ITEM DESCRIPTION

- |                           |                          |
|---------------------------|--------------------------|
| 1. Cooling fan (x6)       | 3. Mounting plate (left) |
| 2. Mounting plate (right) | 4. Protective mask       |

## 1.1 PROTIUM-3000 OC FUEL CELL

Right View

Left View

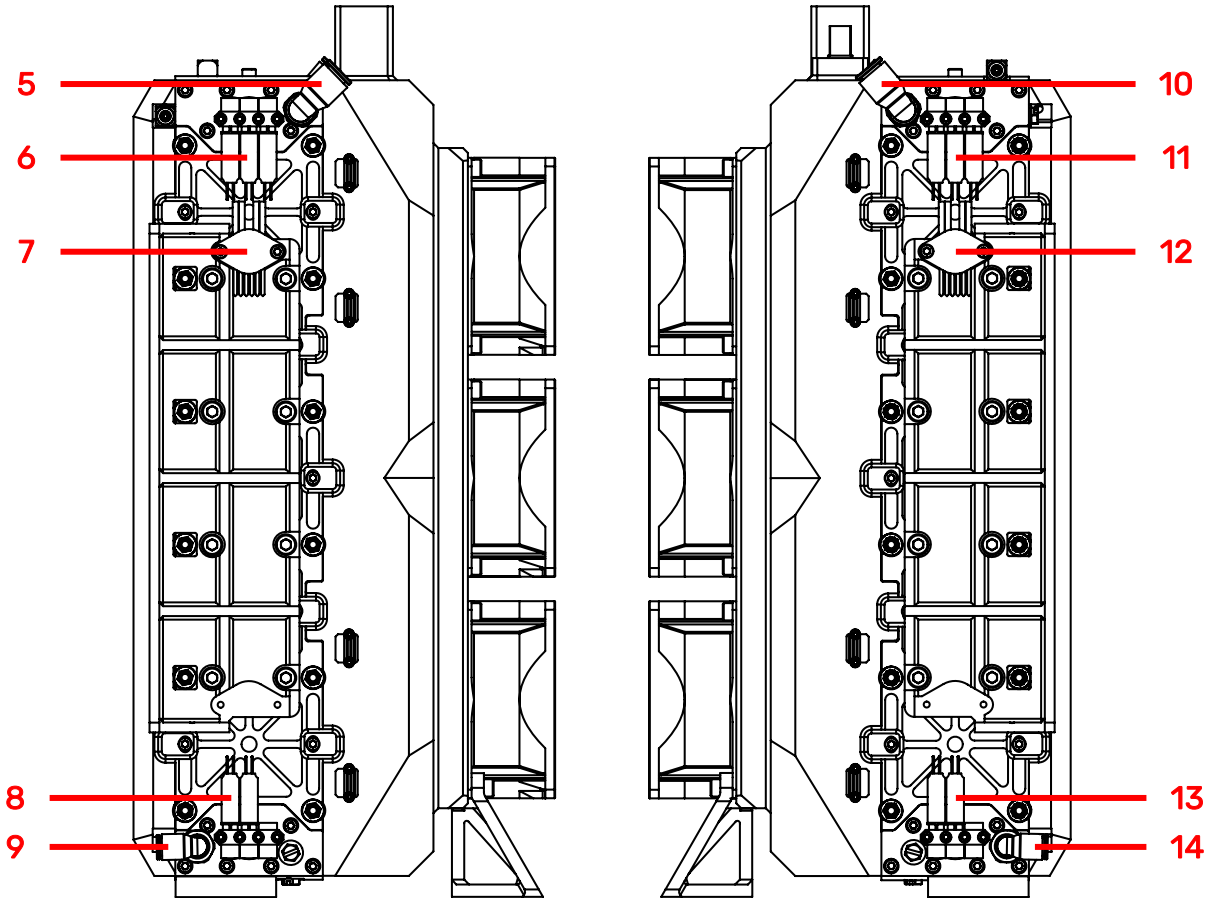

### ITEM DESCRIPTION

- |    |                                 |     |                                |
|----|---------------------------------|-----|--------------------------------|
| 5. | H2 gas inlet connector (right)  | 10. | H2 gas inlet connector (left)  |
| 6. | H2 supply valves (right)        | 11. | H2 supply valves (left)        |
| 7. | Gas pressure sensor 1           | 12. | Gas pressure sensor 2          |
| 8. | H2 purge valves (right)         | 13. | H2 purge valves (left)         |
| 9. | H2 gas outlet connector (right) | 14. | H2 gas outlet connector (left) |

## 1.1 PROTIUM-3000 OC FUEL CELL

*Top View*

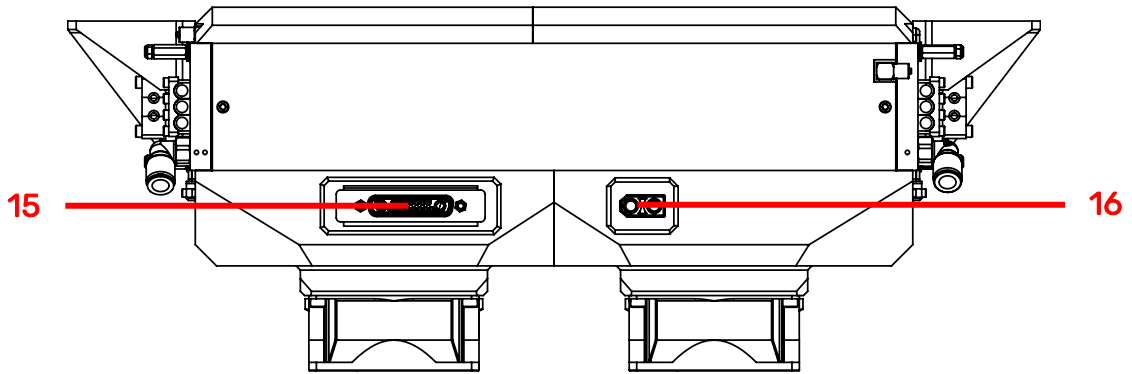

*Bottom View*

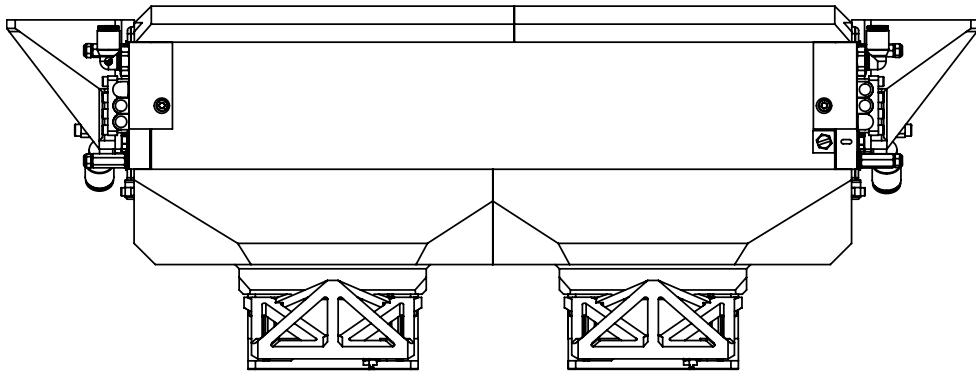

### ITEM DESCRIPTION

15. Power/Signal receptacle

16. Stack power output (XT-90 female)

## 1.2 ELECTRONIC CONTROLLER

Top View

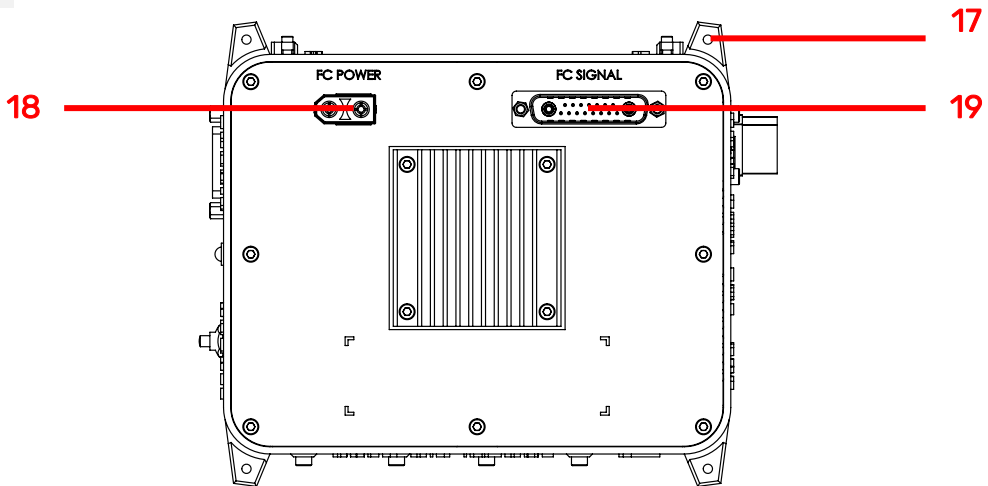

Left View

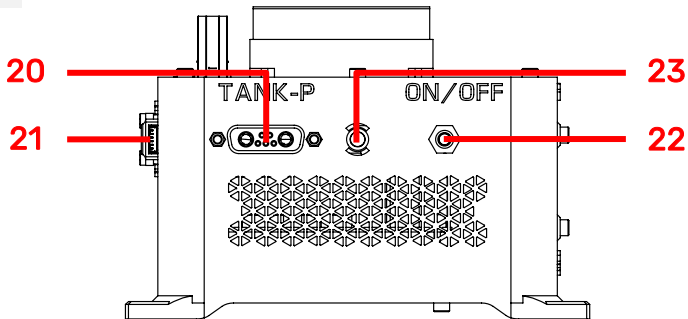

Right View

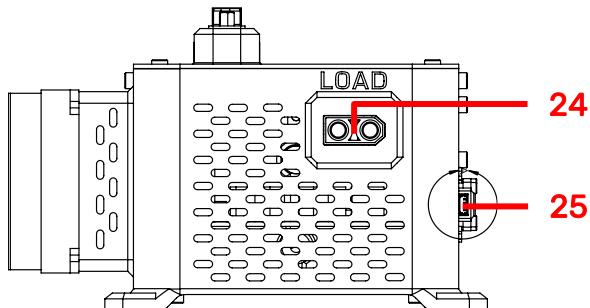

Mfr. Part No:  
53047-0410  
Designed for use  
with 51021-0400

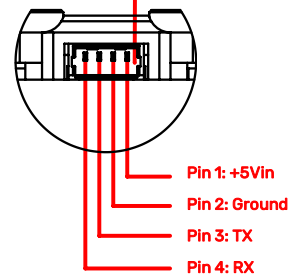

### ITEM DESCRIPTION

17.	Mounting hole (x4)	22.	On/Off push button
18.	Stack power output (XT-90 male)	23.	Status LED
19.	Power/Signal header	24.	Load connector (XT-90 female)
20.	Gas pressure transducer receptacle*	25.	Telemetry transmitter port (4-pin)
21.	Programming port (6-pin)		

\* (Only used with purchase of Spectronik Miniature Gas Pressure Regulator)

## 1.3 STANDARD ACCESSORIES

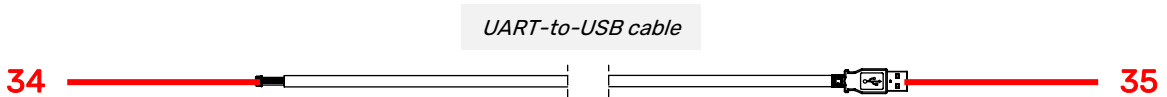
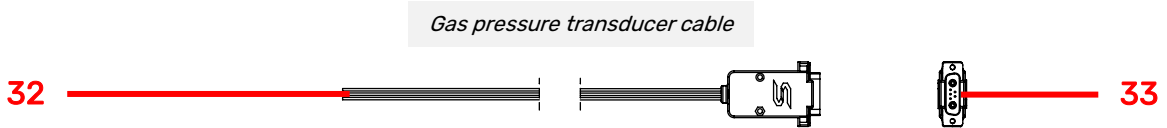
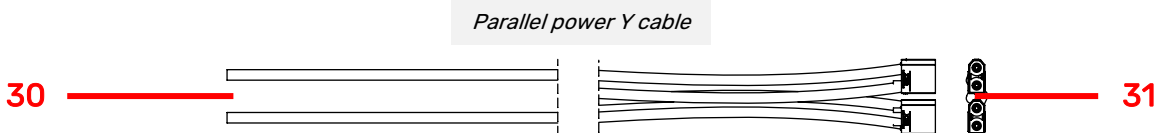
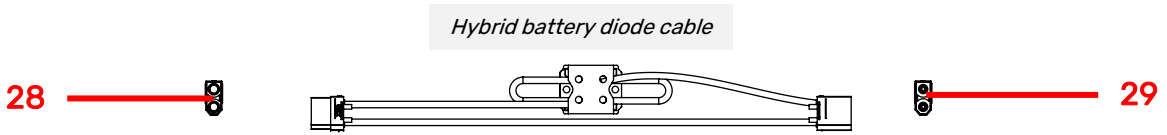
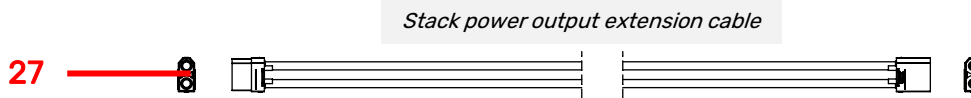
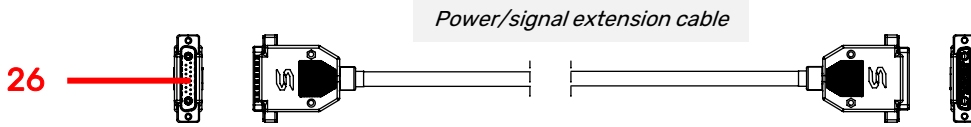

### ITEM DESCRIPTION

- |   |   |
|---|---|
| <b>26.</b> Power/Signal extension cable         | <b>31.</b> Parallel power connectors (XT-90 male) |
| <b>27.</b> Stack power output extension cable   | <b>32.</b> Gas pressure transducer signal wires*  |
| <b>28.</b> Hybrid battery output (XT-90 female) | <b>33.</b> Gas pressure transducer header*        |
| <b>29.</b> Hybrid battery input (XT-90 male)    | <b>34.</b> Molex connector to telemetry port      |
| <b>30.</b> Free-end wires for user's load       | <b>35.</b> USB connector to PC                    |

\* (Only used with purchase of Spectronik Miniature Gas Pressure Regulator)

## 1.4 MECHANICAL DIMENSIONS – PROTIUM-3000 OC

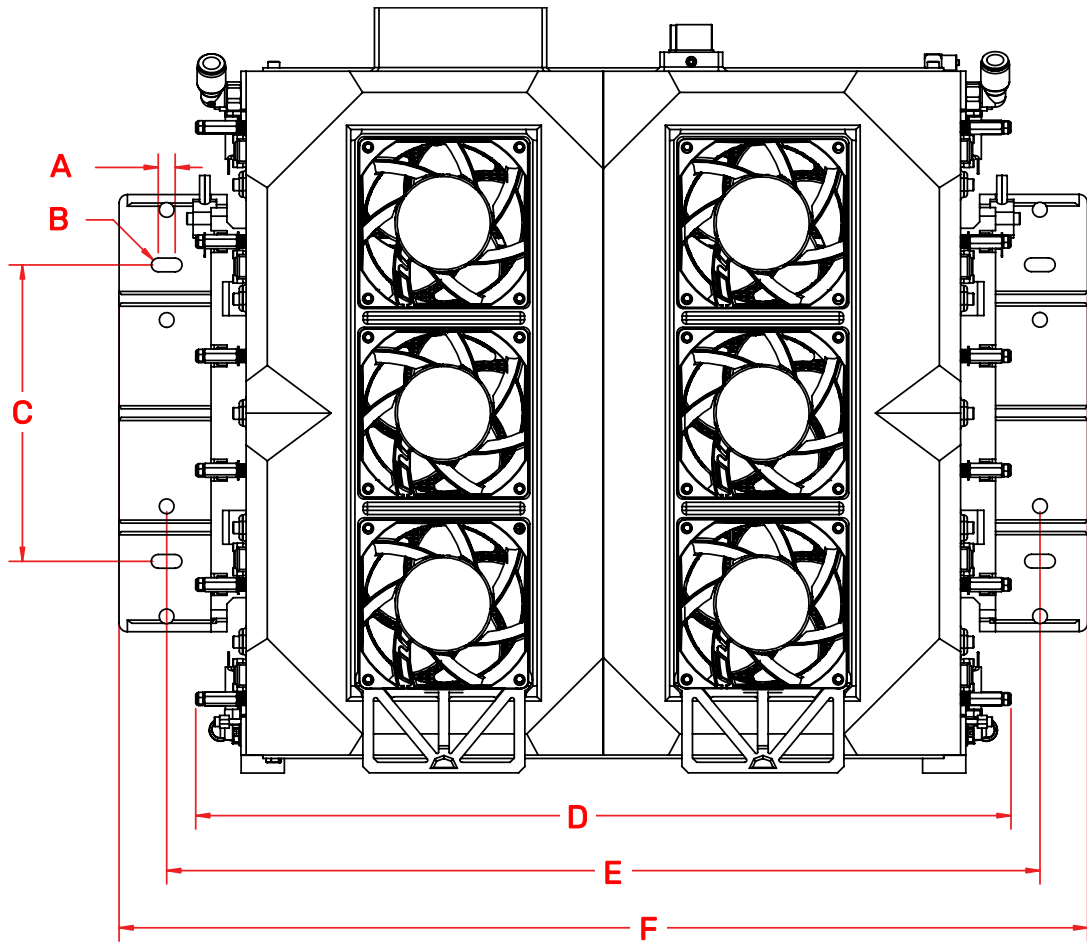

### ALL DIMENSIONS IN MM

A	8.00	D	385.00
B	R3.25	E	412.40
C	140.00	F	457.40



## 1.4 MECHANICAL DIMENSIONS – PROTIUM-3000 OC

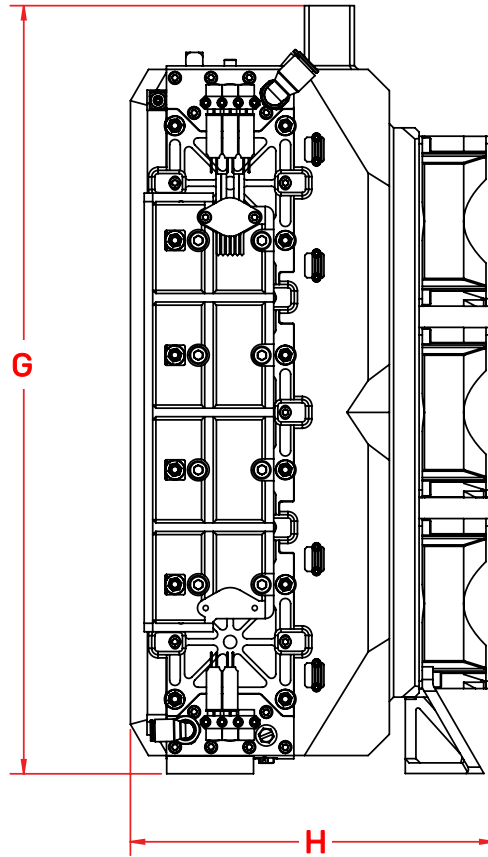

ALL DIMENSIONS IN MM

G 361.60

H 171.20

## 1.5 MECHANICAL DIMENSIONS – ELECTRIC CONTROLLER

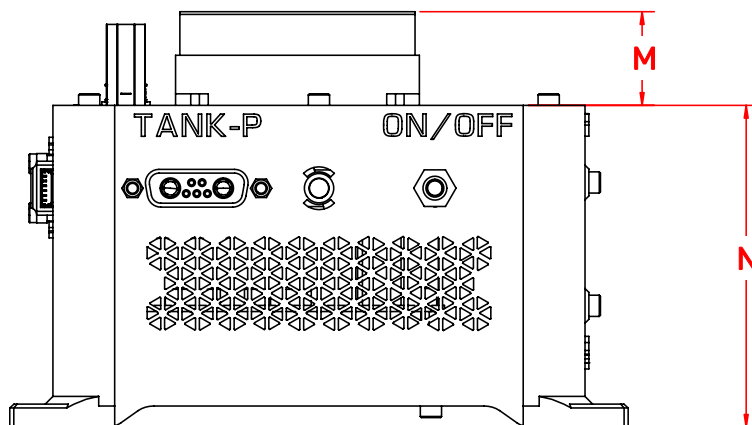
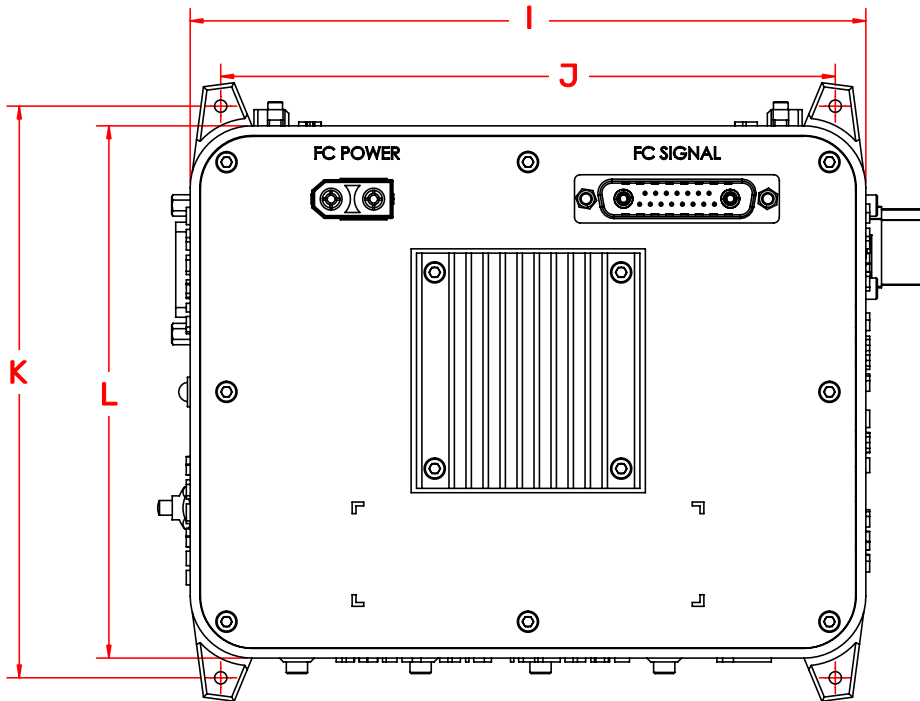

### ALL DIMENSIONS IN MM

I	174.80	L	137.80
J	159.00	M	24.30
K	148.00	N	83.50

## 1.6 MECHANICAL DIMENSIONS – STANDARD ACCESSORIES

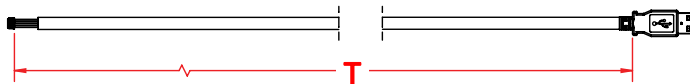
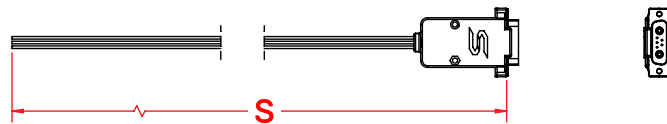
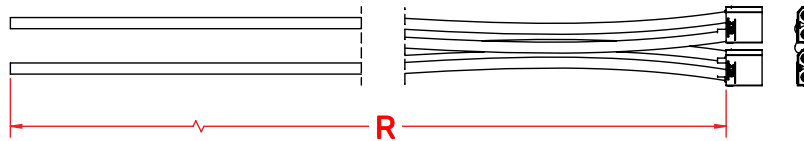
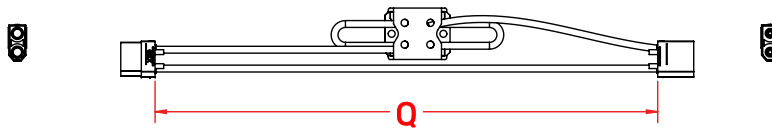
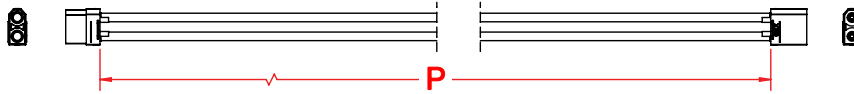
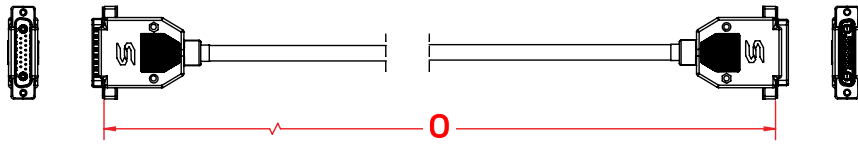

### ALL DIMENSIONS IN MM

O	1000.00	R	1000.00
P	1000.00	S	500.00
Q	300.00	T	1800.00

## 1.7 MOUNTING AND AIR CLEARANCE

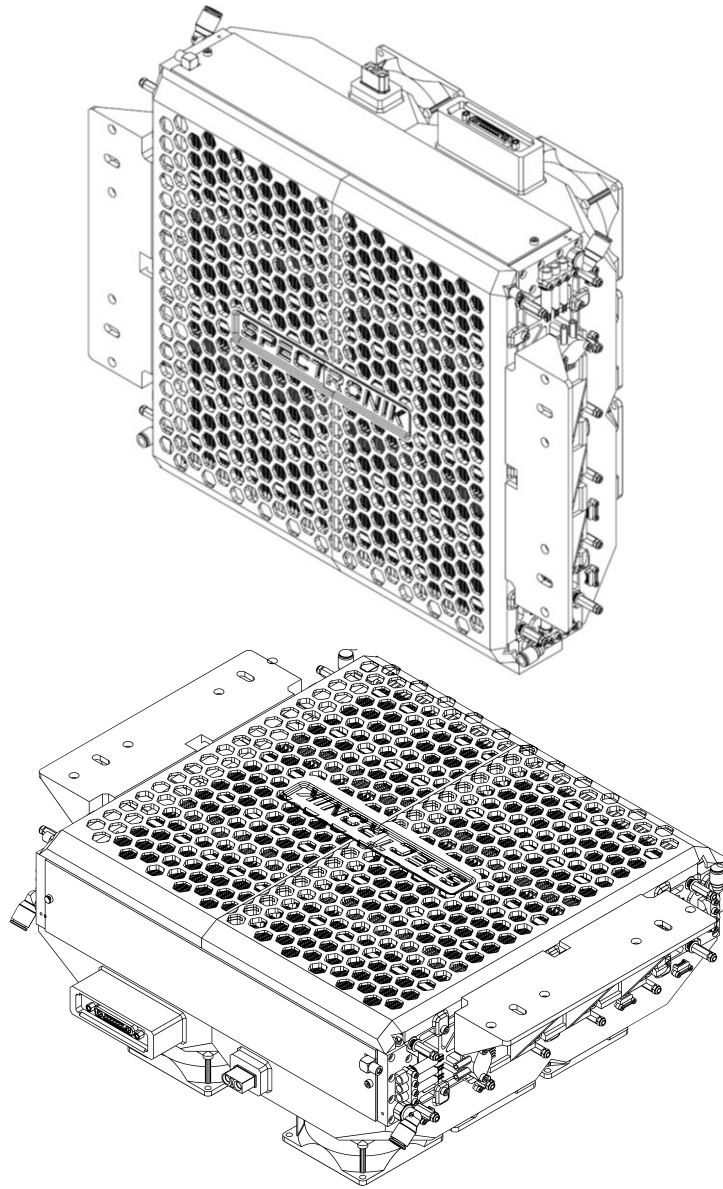

*Recommended Orientations of PROTIUM-3000 OC*

**PROTIUM-3000 OC** cannot be mounted in any orientation due to internal routings of the gas streams within the fuel cell stack. The stack should also be level to ensure water does not get trapped in the Cathode channels, obstructing the oxidant flow and causing potential performance drop and cell damage. Mount PROTIUM-3000 OC vertically upright with the protective mask facing you, or horizontally with the cooling fans blowing downwards.

For optimal oxidant and cooling airflows, it is also recommended that there is **at least 15cm unobstructed clearance from the protective mask and oxidant air inlet**, and **30cm unobstructed clearance from the cooling fans' outlet**.

## 1.8 MECHANICAL DIMENSION – MOUNTING AND CLEARANCE

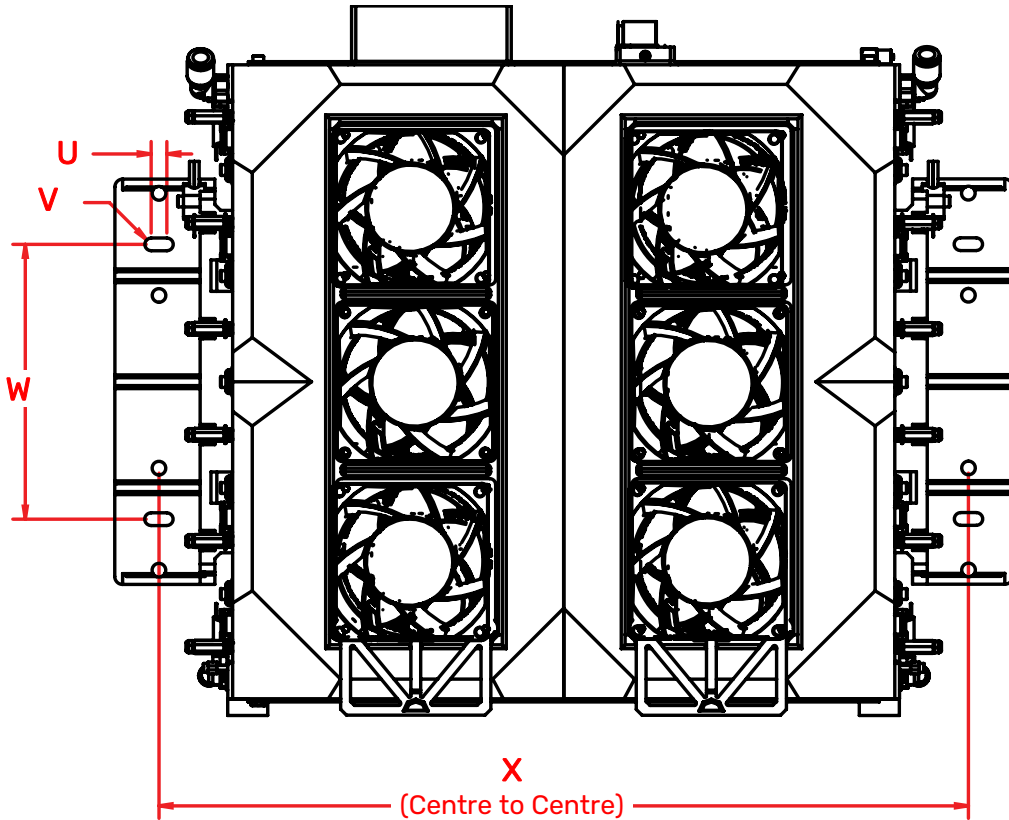

*Dimensions of the mounting holes*

### ALL DIMENSIONS IN MM

U	8.00	W	140.00
V	R3.25	X	412.40

# 2 SPECIFICATIONS

## 2.1 PROTIUM-3000 OC TECHNICAL DATA SHEET

Fuel Cell	PROTIUM-3000 OC
Type	PEM
No. of cells	80
Architecture	Open cathode
Coolant	Air cooled
Rated/gross power	3000/3600W
Rated/gross current	62.5/75A
Voltage output	48-72VDC
Start-up time	30s
Operating ambient temp.	[1,40]°C
Operating altitude without power derating	1500m AGL
System weight	8,565g
Max dimension	458 x 362 x 172mm
Fuel Supply	
Hydrogen gas	Dry, 99.999% purity
Delivery pressure	0.7bar (10 psig)
Fuel consumption @ rated power	36L/min
Gas tubing	PU, 8 x 5.5 (Gas supply inlets) PU, 6 x 4 (Gas purge outlets)
Supply & purge control	Solenoid valves with integrated pressure sensor
Stack leakage checks	Automated via integrated pressure sensors
Electronic Controller	
Processor board	WELTER V1.6
Weight (including casing)	970g
Output connector	XT-90 female (DC unregulated voltage)
Warning & protections	Low voltage, high/low temperature, high/low pressure, low battery, stack leakage
Communication	UART (USB cable for PC connectivity provided)
Data acquisition (DAQ) software GUI	PC app
Remote control	Fan speed, manual purge, remote on-off

## 2.2 VI CURVE

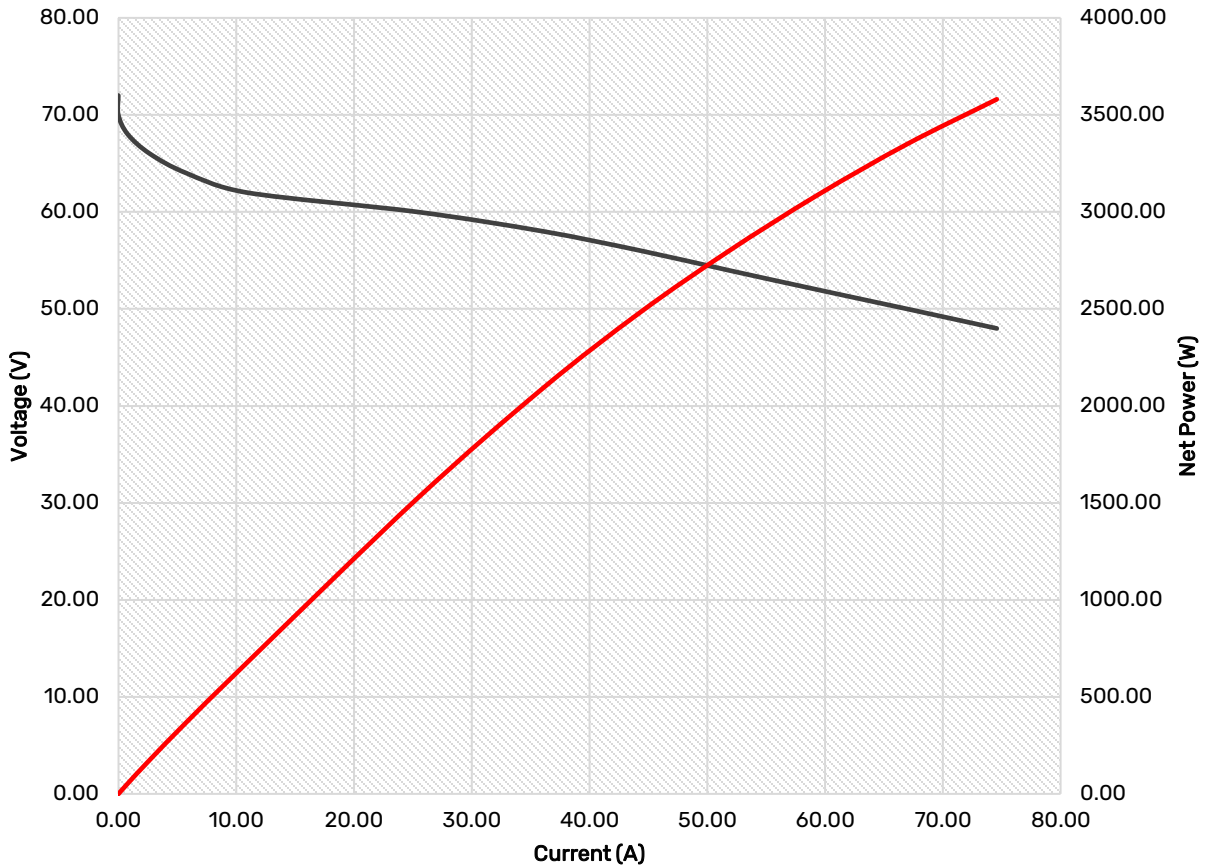

*Nominal polarization curve for a fully conditioned PROTIUM-3000 OC at its Beginning-of-Life (BOL).*

### TEST CONDITIONS

- Ambient temperature: 24°C
- Relative humidity: 60%
- H<sub>2</sub> supply pressure: 10psig
- Dead-ended operation
- Balance-of-plant (BOP) powered by fuel cell
- T<sub>cell</sub> at 3000W: 55°C

## 2.3 SYSTEM BLOCK DIAGRAM

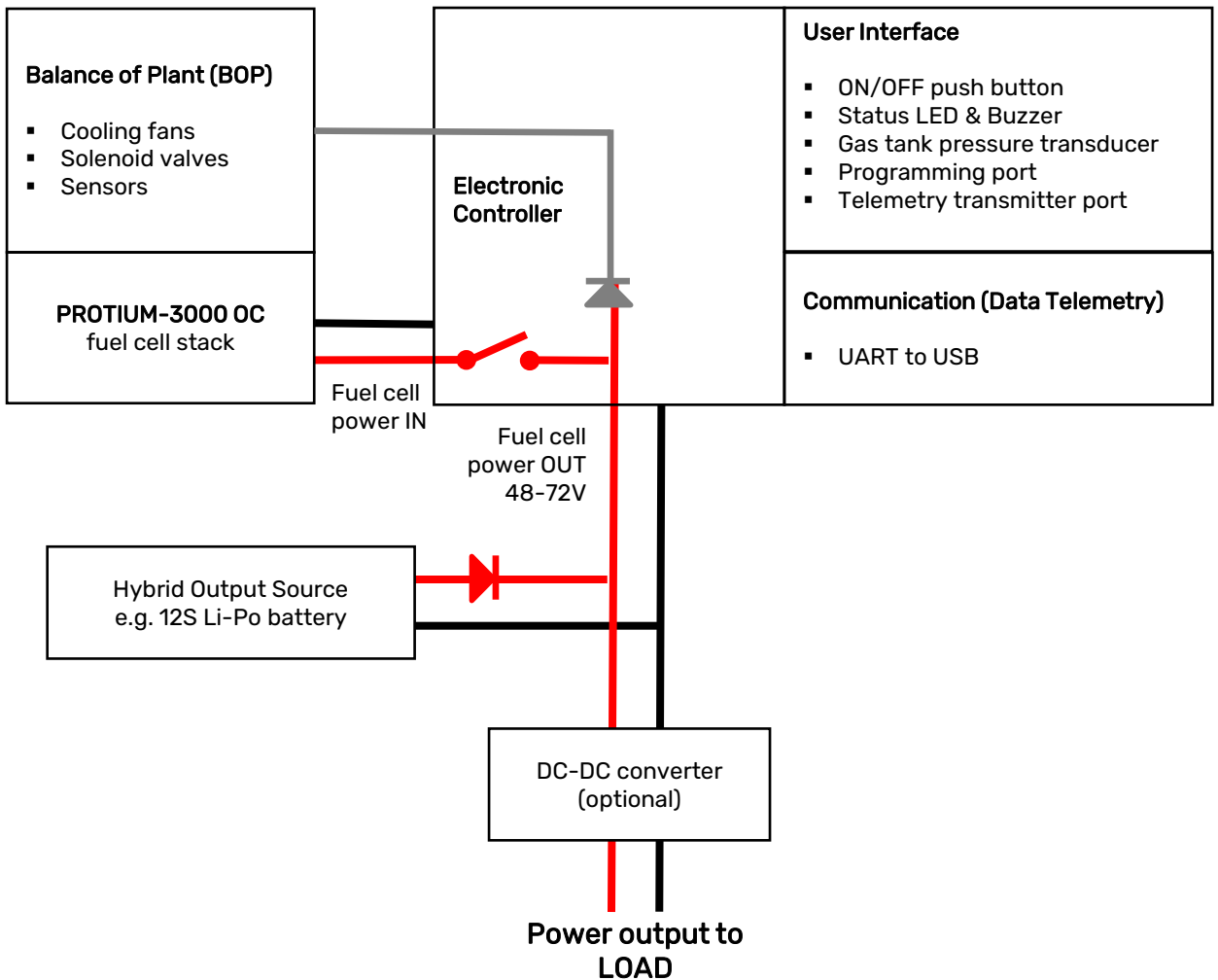

### NOTE

1. A Hybrid Output Source is mandatory. We recommend 12S Lithium-Polymer (Li-Po) battery with at least a capacity of 5000mAh and 30C discharge rate.
2. The Hybrid Output Source serves several functions:
  - To provide external power supply to the Electronic Controller during start-up.
  - To provide external power supply to the Electronic Controller, fuel cell's balance-of-plant (BOP) and LOAD when the fuel cell stack carries out Current Pulsing\*.
  - To provide additional power output to the LOAD in a hybrid parallel configuration with the fuel cell stack output.

\*The fuel cell stack performs periodic Current Pulsing (once every 15-30s, for a duration of around 100ms) to rejuvenate its cell hydration and maintain optimal performance. During Current pulsing, power output from fuel cell stack to LOAD is momentarily cutoff for safety.



## 2.4 SYSTEM OPERATION FLOW

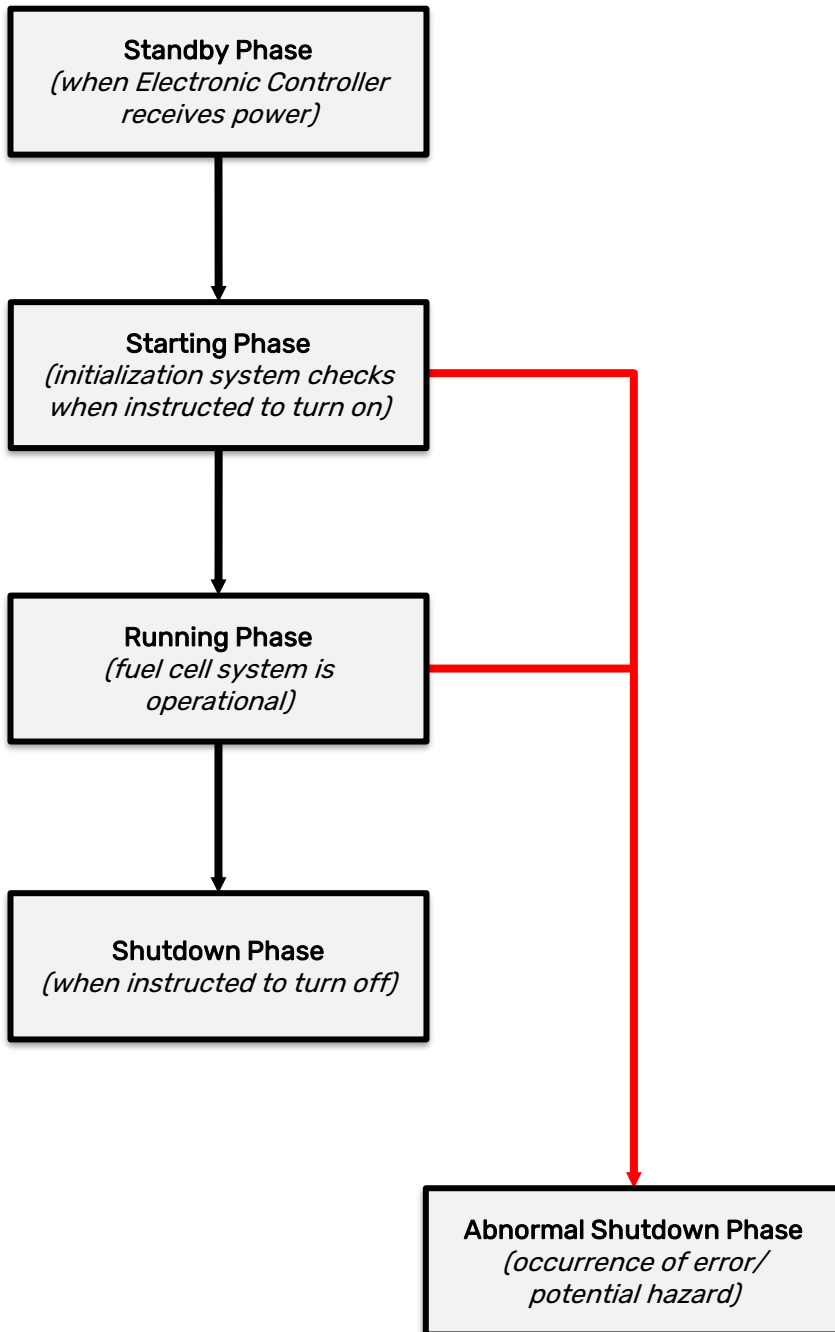

# 3 OPERATING PROCEDURES

## 3.1 SETTING UP PROTIUM-3000 OC

1. Mount PROTIUM-3000 OC securely in the recommended orientation. Ensure that there is nothing blocking the oxidant/cooling air inlet in front of the *protective mask (4)*, and sufficient unobstructed clearance from the *cooling fan (1)* outlets.
2. There are two Hydrogen gas purge tubing left and right of the fuel cell stack. Ensure that they are securely connected to the *H2 gas outlet connectors (9) and (14)*. **Caution: channel the purge tubing far away from the oxidant/cooling air inlet in front of the protective mask.**
3. Connect PROTIUM-3000 OC to the Electronic Controller using the *Power/Signal extension cable (26) and Stack power output extension cable (27)*. For avoidance of doubt, fuel cell's *Power/Signal receptacle (15)* is to be connected to the Electronic Controller's *Power/Signal header (19)*, while fuel cell's *Stack power output (16)* is to be connected to the Electronic Controller's *Stack power output (18)*.
4. Prepare the Hybrid Output Source. We recommend 12S Li-Po battery with at least 5000mAh and 30C discharge rate. Connect your battery to the *Hybrid battery diode cable (29)*. The diode is to prevent the fuel cell from charging the battery.
5. The Hybrid battery and fuel cell are joined together in a parallel configuration using the *Parallel power Y cable*. Connect one of the *parallel power connectors (31)* to the *Hybrid battery output (28)* and another one to the *Electronic Controller's Load connector (24)*.
6. Connect the *Free-end wires (30)* of the Parallel power Y cable to your load. If everything is done correctly, you should see the Hybrid battery's voltage at your load. **Tip: check that the polarity is correct. It is also advisable to put an ON/OFF switch at your load and ensure that it is turned OFF at this time.**
7. PROTIUM-3000 OC has two *H2 gas inlet connectors (5 and 10)*. Connect your Hydrogen gas supply to both inlets. Make sure that your Hydrogen gas supply is OFF at this stage. **Caution: ensure that the gas is regulated to 0.5-0.7bar gauge.**

**Reminder:** ensure that all gas tubing and electrical wire connections are firm and secure.

The setup is now completed and PROTIUM-3000 OC is ready to be turned on.

## 3.2 TURNING ON PROTIUM-3000 OC

1. Connect the *Molex connector (34)* to the *Telemetry transmitter port (25)*, and the *USB connector (35)* to a PC. Launch the Spectronik Data Acquisition Graphic User Interface (DAQ GUI) software. Choose the Com Port, set the Baud Rate (57600) and click the S logo. **Tip:** the latest DAQ GUI software and user manual can be downloaded from the PROTIUM-3000 OC product webpage.
2. A welcome message should appear in the GUI. *Status LED (23)* will blink at 10%. Once the Electronic Controller receives power, it will enter **Standby Phase**, awaiting instruction to initiate.
3. Click START. Alternatively, press and hold the *On/Off push button (22)* for more than 2s. PROTIUM-3000 OC will enter its **Starting Phase** and the message “Low H2 supply” should appear.
4. Turn on your H2 gas supply. **Caution:** *ensure that the gas pressure is regulated to 0.5-0.7bar gauge. Insufficient delivery pressure may cause cell flooding and drop in performance, while excessive pressure may rupture the fuel cell membrane, causing dangerous gas leakage and irreversible cell damage. Ensure that your pressure regulator can provide Hydrogen gas flow rate of more than 40L/min at  $\geq 0.5$  barg output pressure .*
5. PROTIUM-3000 OC will do a series of gas purging and internal diagnostic checks. The cooling fans will turn on. If everything is normal, the system will enter its **Running Phase** – indicated by the message in the GUI and a solid white *Status LED*. All system parameter values can now be seen in the GUI. If there is something wrong, the *Status LED* will flash and error message will appear in the GUI. Follow the basic troubleshooting guide in section 4.

PROTIUM-3000 OC is now ready to power your application.

### NOTES

- Download the DAQ GUI PC app from PROTIUM-3000 OC product webpage and install it on your PC. Follow the instructions in its user manual. If you do not wish to use the DAQ GUI, you can turn on/off PROTIUM-3000 OC by using the physical *On-off push button*. However, you will not be able to monitor the performance nor access some functions.
- **Tip:** A good practice is to prepare a gas pressure regulator that can supply 2x PROTIUM-3000 OC's maximum Hydrogen consumption, i.e. around 80L/min at  $\geq 0.5$  barg.
- Spectronik recommend the [Miniature Gas Pressure Regulator](#) which is designed to be compatible with PROTIUM-3000 OC.

### 3.3 POWERING YOUR LOAD WITH PROTIUM-3000 OC

1. Turn ON your load and draw power as per normal. **Caution:** *never pull the fuel cell voltage below 48V or draw power beyond 3000W.*
2. During **Running Phase**, the following live status of the fuel cell can be monitored from the GUI.

Parameters	Description
FC_V	FC voltage (V)
FC_A	FC current (A)
FC_W	FC power (W)
ENERGY	Energy delivered by the fuel cell during this operation (Wh)
FCT1	FC temperature at location 1 (°C)
FCT2	FC temperature at location 2 (°C)
FAN	Cooling fan duty cycle (%)
H2P1	H <sub>2</sub> supply pressure (Barg)
H2P2	H <sub>2</sub> pressure in FC (Barg)
Tank-P*	Gas tank pressure (Barg)
AuxV	Hybrid Output Source/Li-Po battery voltage (V)

\* only with purchase of Spectronik Miniature Gas Pressure Regulator.

3. During **Running Phase**, you may manually control PROTIUM-3000 OC by clicking commands in the GUI such as Purge and increasing/decreasing the cooling fan speed. **Caution:** *manual control is recommended for advanced users only. For optimal performance, remember to reset to AUTO controls.*
4. During operation, it is normal to see water coming out of the purge tubing. Ensure that water does not drip to any electrical components. **Caution:** *there might be unreacted Hydrogen gas coming out of the purge tubing. Keep away from fire and electric spark. Ensure sufficient ventilation.*

### 3.4 SHUTTING DOWN PROTIUM-3000 OC

1. Turn OFF your load. The cooling fans will turn faster to cool down the fuel cell, before returning to their minimum speed.
2. In the GUI, click END. Alternatively, press and hold the *On/Off push button* for more than 2s. The message "Shutdown Initiated" will appear in the GUI and PROTIUM-3000 OC will enter its **Shutdown Phase** by carrying out a series of shutdown procedures such as turning off the gas supply valves and cooling fans.
3. The message "System OFF" will appear in the GUI. PROTIUM-3000 OC is now turned off. *Status LED* will blink at 60% on standby awaiting the next start-up command.
4. If you do not intend to restart the system soon, turn OFF your Hydrogen gas supply and remove the Hydrogen gas tubing from the *H2 gas inlet connectors*. **Caution: some remaining gas in the tubing will be released into the atmosphere.**
5. Remove the Hybrid Output Source. All the cables can now be disconnected.

**PROTIUM-3000 OC is now ready to be kept for storage.**

# 4 SYSTEM MONITORING, PROTECTIONS & MANUAL CONTROL

## 4.1 MANUALLY CONTROLLING THE PROTIUM-3000 OC

The PROTIUM-3000 OC comes with in-built firmware control that is optimized to bring out its best performance over the applicable ambient environment range. In normal use-case scenario, there is no need for user to fine-tune the parameters. For advanced user who wishes to control the fuel cell manually, the following commands can be entered via the GUI's keyboard function:

Command	PROTIUM-3000 OC action
start <enter>	Starts the system
end <enter>	Enters normal shutdown phase
ver <enter>	Displays the firmware version
f <enter>	Return to automatic cooling fan control
p <enter>	Open the Hydrogen purge valve for 2s. This is useful to remove excess water if cell flooding is suspected due to decreasing power output.
= (equal)	Increase cooling fan speed by 5% (manual control)
- (hyphen)	Decrease cooling fan speed by 5% (manual control)
0	Increase cooling fan speed by 1% (manual control)
9	Decrease cooling fan speed by 1% (manual control)

**Tip:** you may also long press the *ON/OFF push button* by >2s to turn ON/OFF the system instead of entering "start" and "end" command via the GUI.

## 4.2 SYSTEM WARNING & PROTECTIONS

PROTIUM-3000 OC has several in-built protections. The LED will flash and error message will appear in the GUI. Follow the basic troubleshooting guide below. Most errors should be rectified once the suggested corrective action has been done and the system restarted.

**If the error persists, contact [hello@spectronik.com](mailto:hello@spectronik.com).**

### 4.3 SYSTEM WARNING & PROTECTIONS – STARTING PHASE

#### Warning messages during Starting Phase:

Message	Meaning/ Corrective Action
Gas Tank Not Detected *	Either the gas tank communication cable is not connected or the tank is empty.
Gas Tank Pressure Low *	There is less than 20 Bar remaining in the gas tank.
Gas Tank Insufficient Pressure *◎	There is not enough pressure in the gas tank to start.
Low H2 Supply	Hydrogen supply pressure is low and the system will wait up to 1min for correction. Please check and correct the delivery pressure.
Error: Low H2 Supply ◎	Hydrogen is not correctly supplied within the stipulated time limit. Check and ensure sufficient Hydrogen supply and correct delivery pressure. Restart the system.
Over Pressure	Hydrogen supply pressure is too high and the system will wait for 1min. Reduce the delivery pressure.
Error: Over Pressure ◎	Hydrogen is not properly supplied within the stipulated time limit. Check and ensure sufficient Hydrogen supply and correct delivery pressure. Restart the system.
High Temperature	Stack temperature is too high and the system will wait for 1min.
Error: High Temperature ◎	Disconnect everything and wait for system to cool down and restart after 10min. If the problem persists, internal temperature sensor might have been compromised. Contact Spectronik.
Error: FC Over Cooled ◎	Stack temperature is too low. Wait for ambient temperature to increase and restart the system.
FC Sealing Compromised ◎	Possible stack leakage. Check and ensure all gas tubing and connectors are securely connected.
Error: Low Voltage ◎	Stack open circuit voltage is too low. Check and ensure sufficient hydrogen supply and correct delivery pressure. Restart after 1 min.
Purge Valve Error ◎	The Purge Valves might not be activating. If the environment is cold, try heating it up.
Supply Valve Error ◎	The Supply Valves might not be activating. If the environment is cold, try heating it up.
Gas Tank Outlet is Leaking *◎	There has been an unwarranted pressure drop between Gas Tank and Supply Valves. Please verify gas line connections.
Aux V supply, incorrect Voltage ◎	Check that the correct Li-Po (12S) is connected, and that it is sufficiently charged. The voltage must be between 46.4V-51.6V.

◎ *Emergency Shutdown = **Abnormal Shutdown Phase** would be activated*

\* *with purchase of Spectronik Miniature Gas Pressure Regulator*

## 4.4 SYSTEM WARNING & PROTECTIONS – RUNNING PHASE

### Warning messages during Running Phase:

Message	Meaning/ Corrective Action
High Temperature ●	Stack temperature is too high. The fuel cell power output to load will be temporarily disconnected for 5s for system to recover. LED will blink. Reduce your load.
Error: High Temperature ●	Stack temperature is too high. Disconnect everything and wait for system to cool down and restart after 10min. If the problem persists, internal temperature sensor might have been compromised. Contact Spectronik.
Low Temperature ●	Stack temperature is low. LED will blink.
Error: FC Over Cooled ●	Stack temperature is too low for operation.
Low Voltage ●	Stack Voltage at minimum threshold of 0.6V/cell.
Error: Low Voltage ●	Stack Voltage below safety threshold limit.
Low H2 Supply ●	Hydrogen supply pressure is low and the fuel cell power output to load will be temporarily disconnected. LED will blink. Check and ensure sufficient Hydrogen supply and correct delivery pressure.
Error: Low H2 Supply ●	Hydrogen supply pressure is too low. Check and ensure sufficient Hydrogen supply and correct delivery pressure. Restart the system.
High H2 Supply Pressure ●	Hydrogen supply pressure is too high and the supply valve will be temporarily shut off. Reduce the delivery pressure.
Error: High H2 Supply Pressure ●	Hydrogen supply pressure is too high. Check and ensure sufficient Hydrogen supply and correct delivery pressure. Restart the system.
External Batt/ Power Supply Low ●	The Hybrid Li-Po battery voltage is low. Prepare to end the operation.
Gas Tank Running Low *●	The pressure in the gas tank is below 20 Bar.
Gas Tank Depleting *●	The pressure in the gas tank is below 10 Bar.
<p>● <i>Emergency Shutdown = <b>Abnormal Shutdown Phase</b> would be activated</i></p> <p>● <i>Status LED flashing at 80% to alert warning during <b>Running Phase</b></i></p> <p>* <i>with purchase of Spectronik Miniature Gas Pressure Regulator</i></p>	



## 4.5 SYSTEM WARNING & PROTECTIONS – LED STATUS & OTHER MESSAGES

### LED Status:

Phase	Blink % (at 1Hz)	Meaning
Power ON/ Standby Phase	10%	5s after start-up power is provided into the Electronic Controller, LED will blink at 10%, indicating that the system is ready to receive its "start" command
Starting Phase	40%	Executing <b>Starting Phase</b> procedures
Running Phase	100%	System in normal <b>Running Phase</b>
Running Phase	80%	System warning during <b>Running Phase</b>
After shutdown	60%	System off due to normal shutdown and on standby for the next "start" command
Abnormal Shutdown Phase	0%	System off due to abnormal shutdown

### Other messages:

Message	Meaning
Fan PWM auto	Cooling fans control is in auto mode
Fan PWM manual	User has manually changed the fan setting
Mileage	Cumulative Watt-Hour of the system
Shutdown Initiated	Entering normal <b>Shutdown Phase</b>
Abnormal Shutdown Initiated	Entering <b>Abnormal Shutdown Phase</b> due to an error
System off	System is turned off and ready to restart at the next command

# 5 MAINTENANCE AND STORAGE

## 5.1 MAINTENANCE FOR PROTIUM-3000 OC

When not in use, Spectronik recommends that PROTIUM-3000 OC is reconditioned at least once a month.

1. Set up PROTIUM-3000 OC as per instructions in Section 3, using a DC electronic load in lieu of your regular load.
2. After the system enters "Running Phase", set constant voltage (CV) load of 48V and run the system for 1h. The fuel cell should recover to its maximum rated power output.

**PROTIUM-3000 OC is now ready for usual operation or can be stored again for future use.**

## 5.2 STORAGE

Keep PROTIUM-3000 OC in an open, cool (standard room temperature of 25°C) and dry place.