

S SPECTRONIK

PROTIUM-1000

FUEL CELL SYSTEM

USER GUIDE – P-1000-1.0-1.0

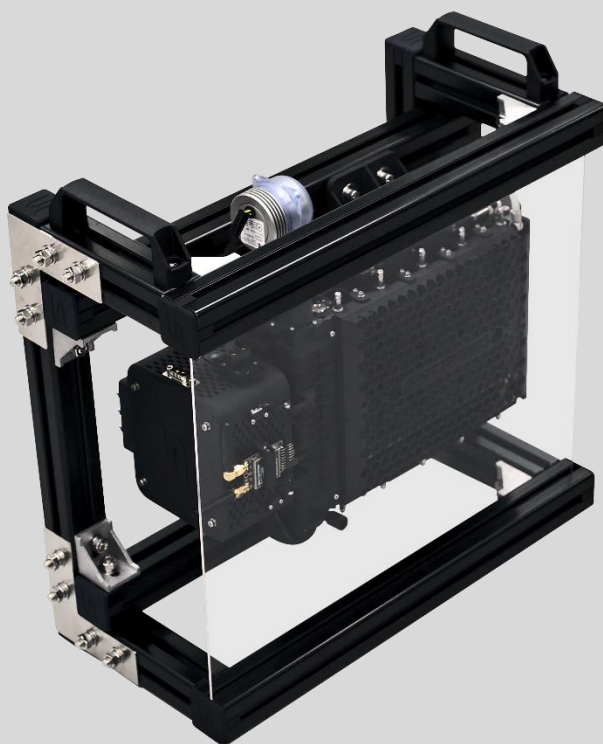

SAFETY, HANDLING & SUPPORT

WARNING: *Read all the safety information below before using PROTIUM-1000. Failure to follow these safety instructions could result in fire, electric shock, or other injuries, or damage to PROTIUM-1000 Fuel Cell System (PROTIUM-1000) or other property.*

Handling Handle PROTIUM-1000 with care. It is made of thin sheet metal, graphite, and plastic and has sensitive electrochemical membrane and components inside. PROTIUM-1000 is not designed for extreme conditions, rough handling, vibration, shock or drop. Keep PROTIUM-1000 away from heat, flame, strong sunlight, water, dust, soil or mud. Do not use a damaged PROTIUM-1000.

Repairing PROTIUM-1000 is assembled under high compression. Do not disassemble or tamper with PROTIUM-1000. Do not troubleshoot, repair or replace any component by yourself.

Hydrogen Use only high purity (99.999%) dry Hydrogen gas with PROTIUM-1000. Hydrogen is a colorless, odorless and highly flammable gas. It is non-toxic but can cause asphyxiation. Follow all local rules and regulations for safe handling, storage and usage of Hydrogen gas. Do not smoke when operating PROTIUM-1000.

Ventilation Operate PROTIUM-1000 in a well ventilated environment. Fresh air intake for the fuel cell oxidant blower, cooling air entry from the front of the protective mask, and hot air exit from the cooling fans shall not be obstructed or restricted.

Purging PROTIUM-1000 periodically flushes its anode during operation, releasing Hydrogen gas and water from the Hydrogen gas outlet. Do not block the Hydrogen gas outlet. Do not bring flame or electric spark close to the Hydrogen gas outlet. It is advisable to attach a longer gas tubing to the Hydrogen gas outlet connector and safely guide the purge exhaust far away from the fuel cell.

CAUTION: *Always put the Hydrogen gas outlet tubing behind the cooling fan and never in front of the fuel cell stack. Purged Hydrogen mixed with air intake into the fuel cell's cathode channels may cause fire and irreversible damage to the fuel cell.*

Connectors, ports and buttons Never force a connector into a port or apply excessive pressure to a button. If the connector and port do not join with reasonable ease, they probably do not match. Check for obstructions and ensure that the connector matches the correct port.

Disposal and recycling As PROTIUM-1000 contains electronic components, it must be disposed of separately from household waste. When PROTIUM-1000 reaches its end of life, follow local laws and regulations for proper disposal and recycling options.

High-consequence activities PROTIUM-1000 is a customized system with pending safety tests and certifications. It is not intended for use where the failure of the system could lead to death, personal injury or severe environmental damage.

Disclaimer Every effort has been made to ensure that the information in this manual is accurate. This manual serves to adequately recommend safe operating procedures, but shall not be treated as comprehensive. Do not use PROTIUM-1000 in any other way than the one recommended in this manual. Spectronik reserves the right to change system specifications, appearance or discontinue the product at any time.

Warranty Spectronik warrants the included hardware product and accessories against defects in materials and workmanship for the first 30 days after delivery. Spectronik does not warrant against normal wear and tear, nor damage caused by accident or abuse.

To obtain service, contact hello@spectronik.com

1 OVERVIEW

1.1 PROTIUM-1000 FUEL CELL

Front view

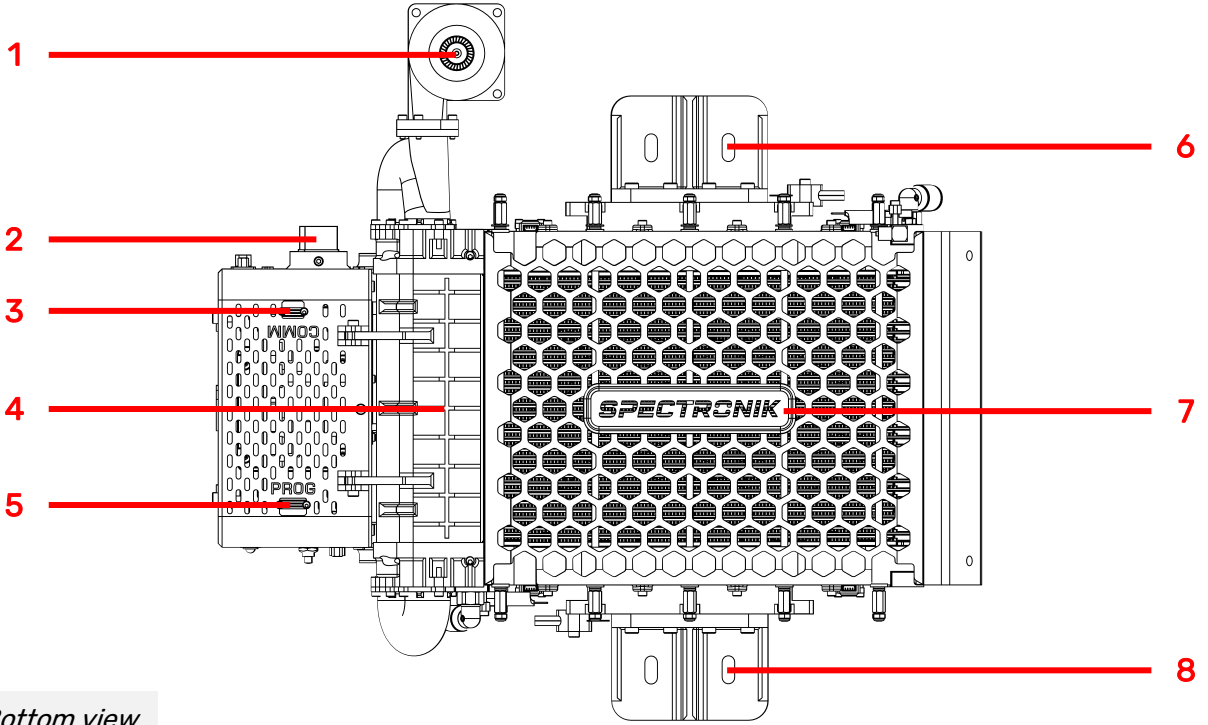

Bottom view

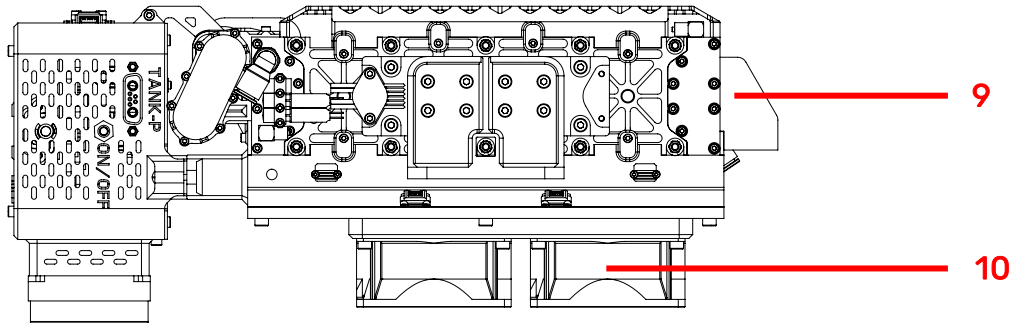

ITEM DESCRIPTION

- | | |
|---------------------------------------|----------------------------|
| 1. Oxidant blower | 6. Mounting plate (top) |
| 2. Load connector (XT-90 female) | 7. Protective mask |
| 3. Telemetry transmitter port (4-pin) | 8. Mounting plate (bottom) |
| 4. Oxidant flow manifold | 9. Cathode outlet duct |
| 5. Programming port (6-pin) | 10. Cooling fan (x2) |

1.1 PROTIUM-1000 FUEL CELL

Bottom View

Top View

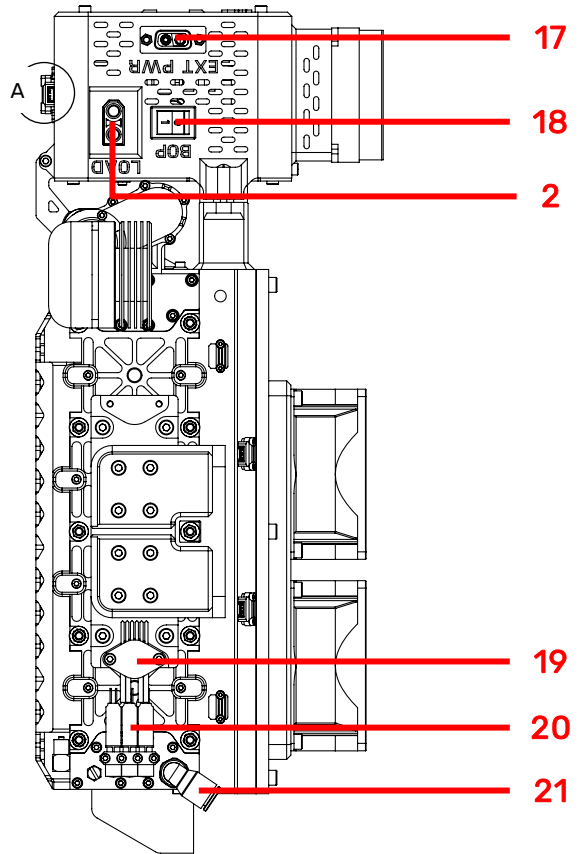
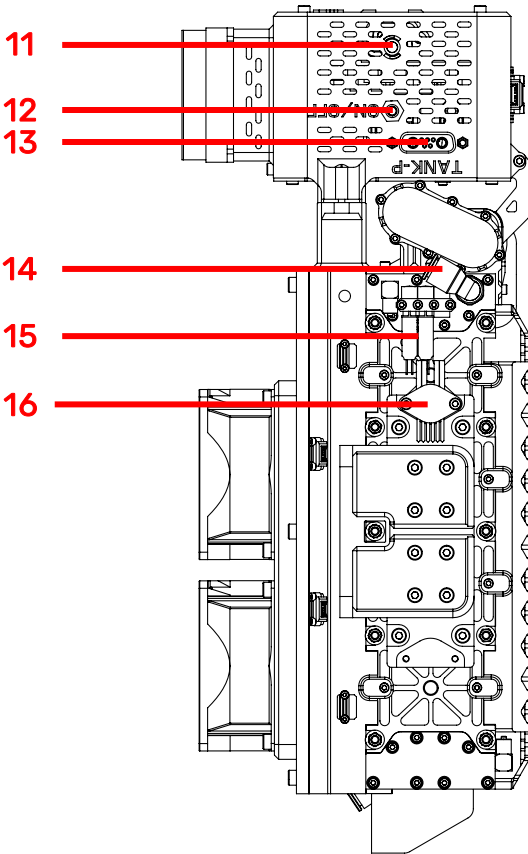
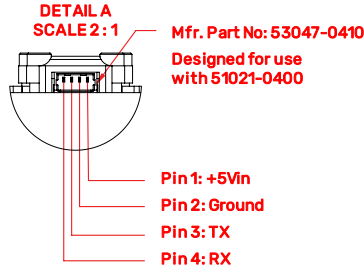

ITEM DESCRIPTION

- | | |
|---|--|
| 11. Status LED | 17. External power supply receptacle |
| 12. On/Off push button | 18. Balance-of-plant (BOP) switch |
| 13. Gas pressure transducer receptacle* | 19. Gas pressure sensor 1 |
| 14. H2 gas outlet connector | 20. H2 supply valves |
| 15. H2 purge valves | 21. H2 gas inlet connector |
| 16. Gas pressure sensor 2 | * (Only used with purchase of Spectronik Miniature Gas Pressure Regulator) |

1.2 STANDARD ACCESSORIES

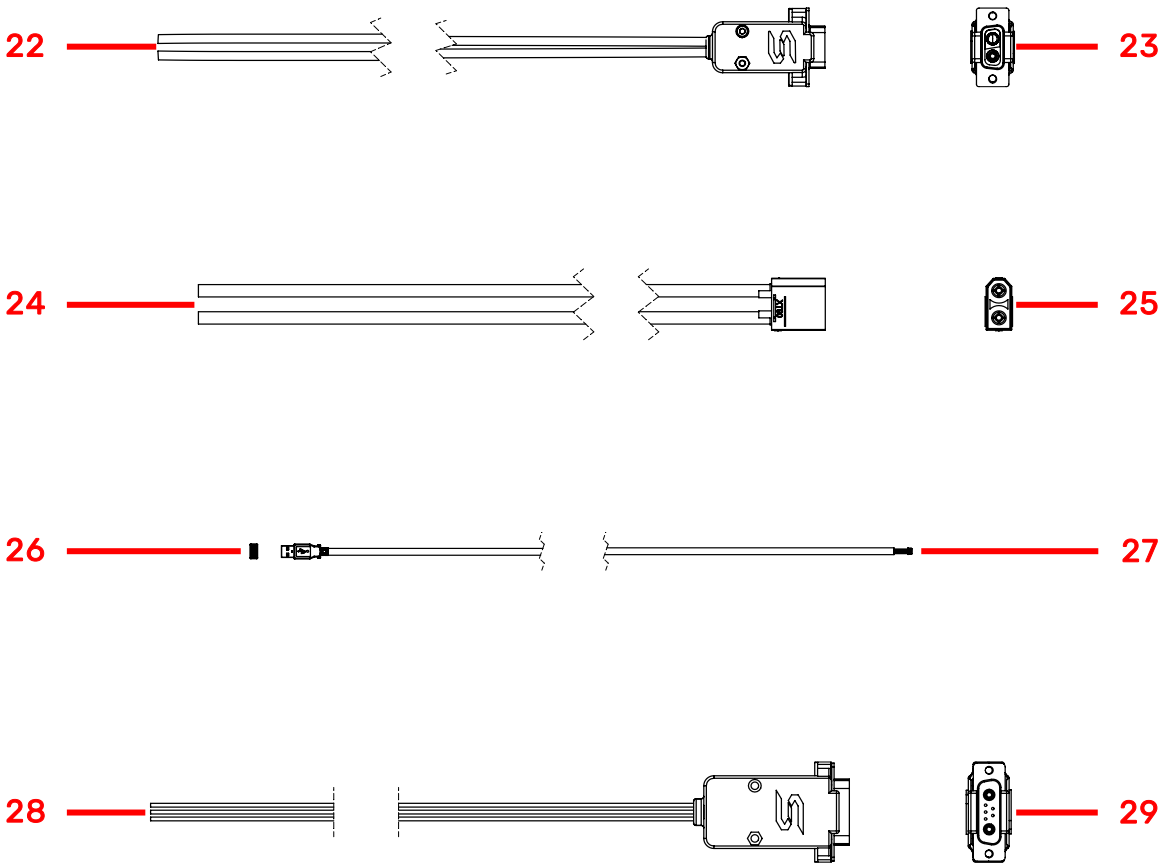

ITEM DESCRIPTION

- | | |
|---|--|
| 22. Free-end wires for user's power supply | 26. USB connector to PC |
| 23. External power supply header | 27. Molex connector to telemetry port |
| 24. Free-end wires for user's load | 28. Gas pressure transducer signal wires* |
| 25. Load connector (XT-90 male) | 29. Gas pressure transducer header* |

* (Only used with purchase of Spectronik Miniature Gas Pressure Regulator)

1.3 MECHANICAL DIMENSIONS – PROTIUM-1000

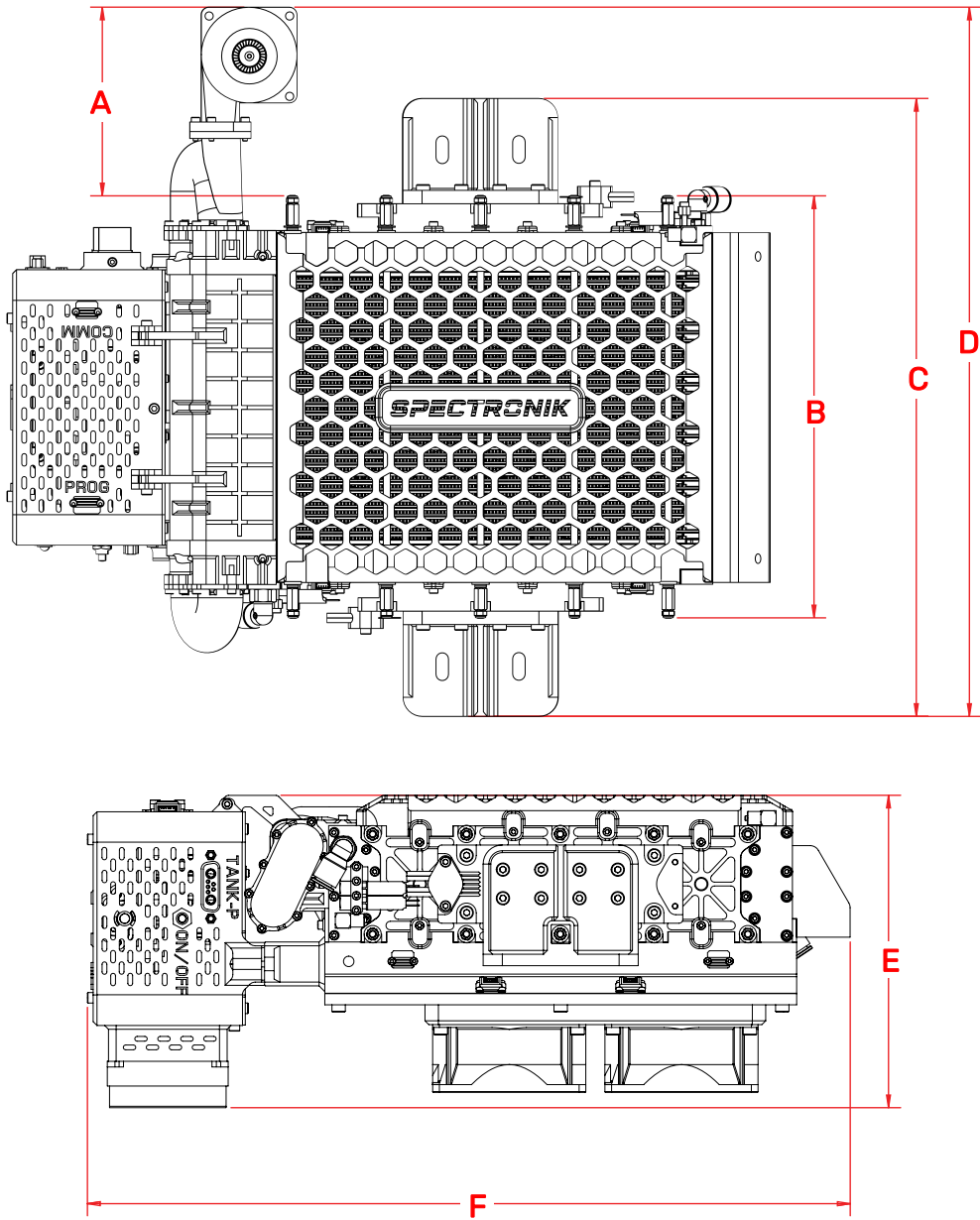

ALL DIMENSIONS IN MM

A	98.60	D	370.60
B	220.50	E	163.75
C	322.90	F	398.50

1.4 MECHANICAL DIMENSIONS – STANDARD ACCESSORIES

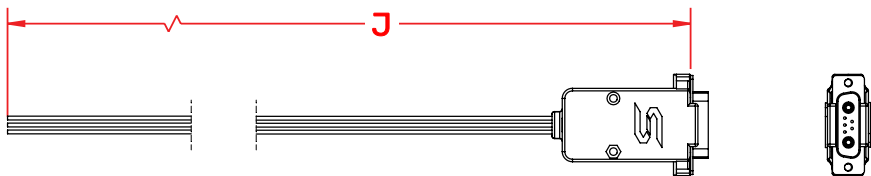
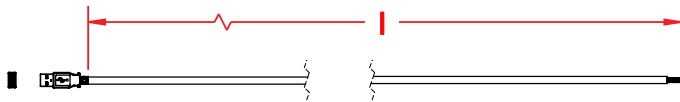
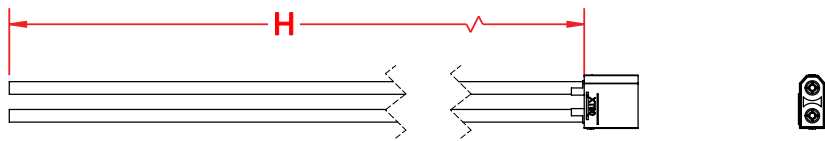

ALL DIMENSIONS IN MM

G	1000.00	I	1800.00
H	1000.00	J	500.00

1.5 MOUNTING AND AIR CLEARANCE

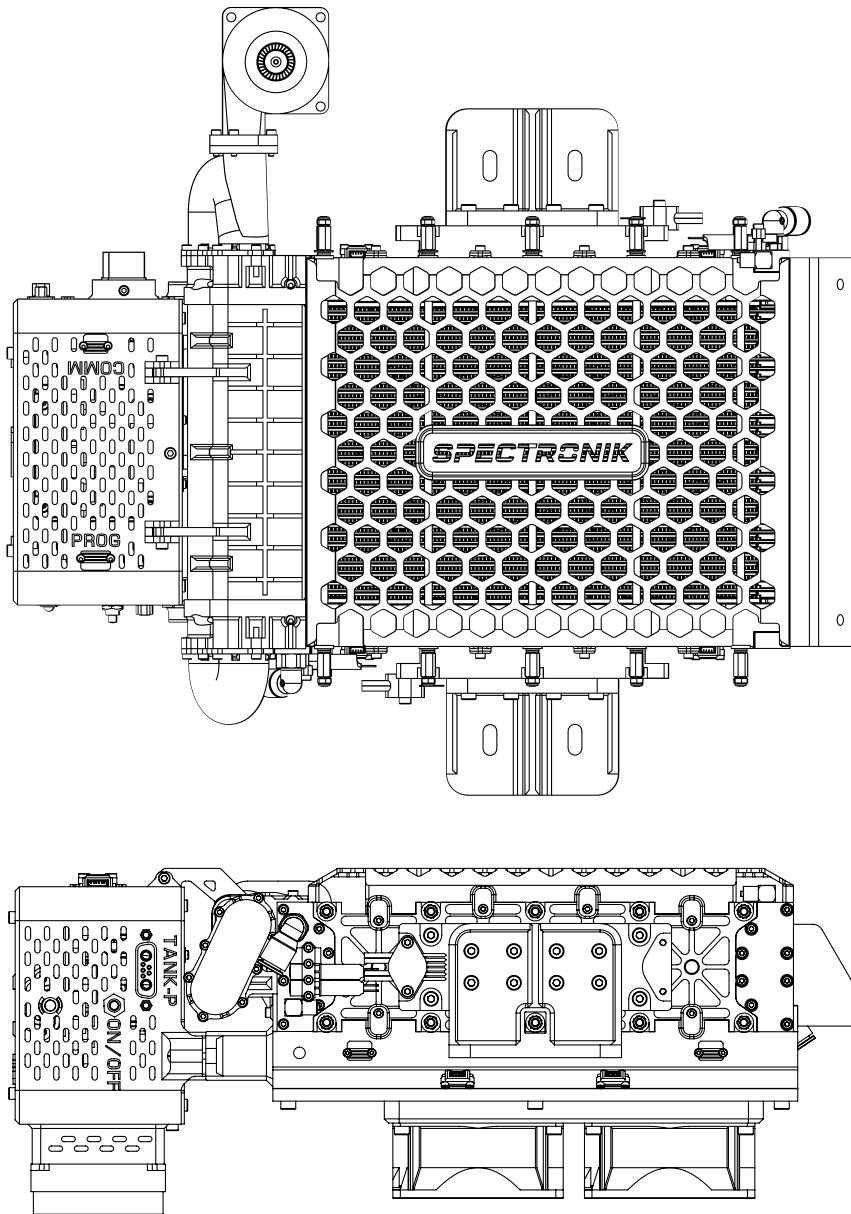

Recommended Orientations of PROTIUM-1000

PROTIUM-1000 cannot be mounted in any orientation due to internal routings of the gas streams within the fuel cell stack. The stack should also be level to ensure water does not get trapped in the Cathode channels, obstructing the oxidant flow and causing potential performance drop and cell damage. Mount PROTIUM-1000 in one of the two recommended orientations above – vertically with the protective mask facing you or horizontally with the cooling fans blowing downwards.

For optimal oxidant and cooling airflows, it is also recommended that there is **at least 15cm unobstructed clearance from the protective mask and oxidant blower inlet**, and **30cm unobstructed clearance from the cooling fans' outlet**.

1.6 MECHANICAL DIMENSION – MOUNTING AND CLEARANCE

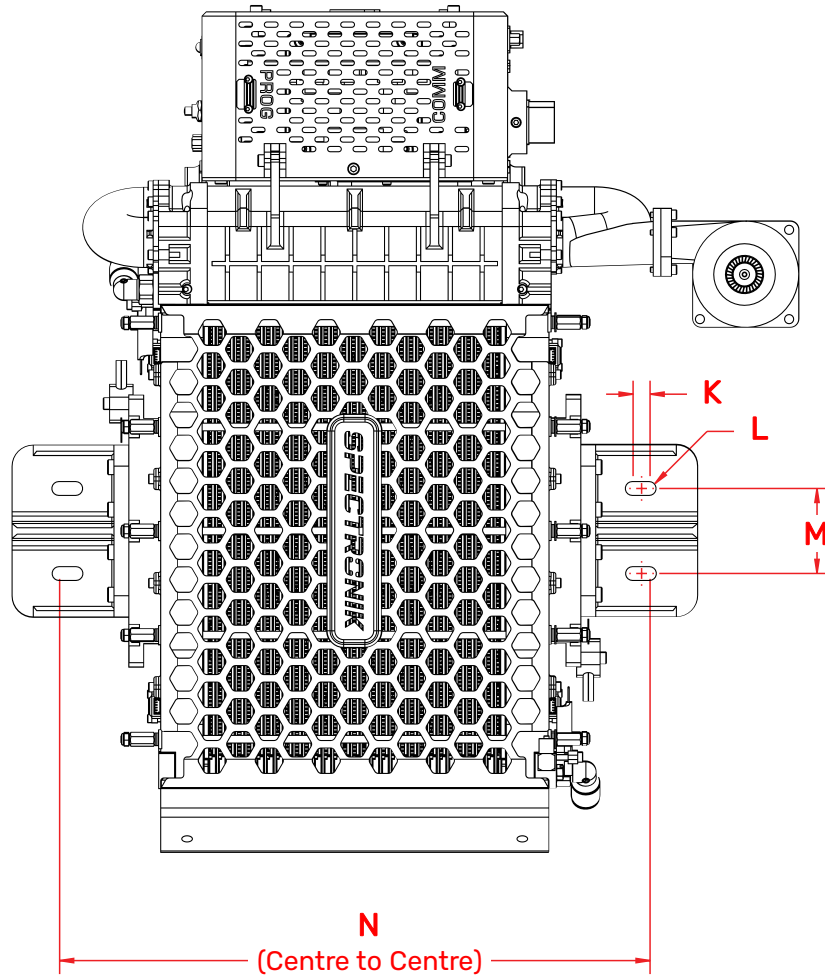

Dimensions of the mounting holes

ALL DIMENSIONS IN MM

K	8.00	M	40
L	R3.25	N	270.60

2 SPECIFICATIONS

2.1 PROTIUM-1000 TECHNICAL DATA SHEET

Fuel Cell	PROTIUM-1000
Type	PEM
No. of cells	30
Architecture	Closed cathode
Coolant	Air cooled
Rated/gross power	1000/1200W
Rated/gross current	55.5/66.6A
Voltage output	18-27VDC
Start-up time	30s
Operating ambient temp.	[-10,45]°C
Operating altitude without power derating	1500m AGL
System weight	4,640g
Max dimension	399 x 164 x 371 mm
Fuel Supply	
Hydrogen gas	Dry, 99.999% purity
Delivery pressure	0.7bar (10 psig)
Fuel consumption @ rated power	12.5L/min
Gas tubing	PU, 8 x 5.5
Supply & purge control	Solenoid valves with integrated pressure sensor
Stack leakage checks	Automated via integrated pressure sensors
Electronic Controller	
Processor board	FEATHER V1.4
External power supply requirement	15-90V, 150W max
Weight (including casing)	810g
Output connector	XT-90 female (DC unregulated voltage)
Warning & protections	Low voltage, high/low temperature, high/low pressure, low external power supply, stack leakage
Communication	UART (USB cable for PC connectivity provided)
Data acquisition (DAQ) software GUI	PC app
Remote control	Fan speed, blower speed, manual purge, remote on-off

2.2 VICURVE

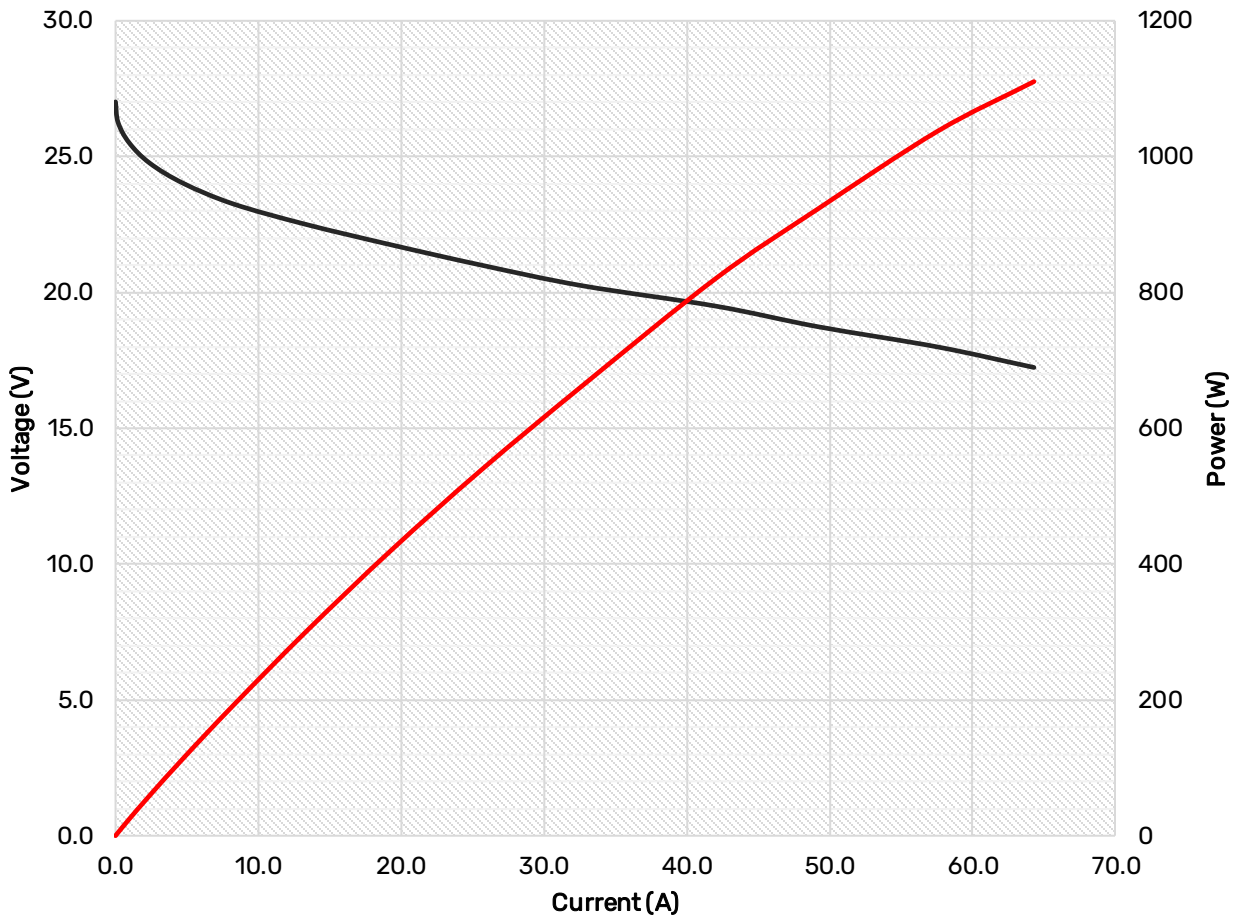

Nominal polarization curve for a fully conditioned PROTIUM-1000 at its Beginning-of-Life (BOL).

TEST CONDITIONS

- Ambient temperature: 24°C
- Relative humidity: 60%
- H₂ supply pressure: 10psig
- Dead-ended operation
- Balance-of-plant (BOP) powered by fuel cell
- T_{cell} at 1000W: 66°C

2.3 SYSTEM BLOCK DIAGRAM

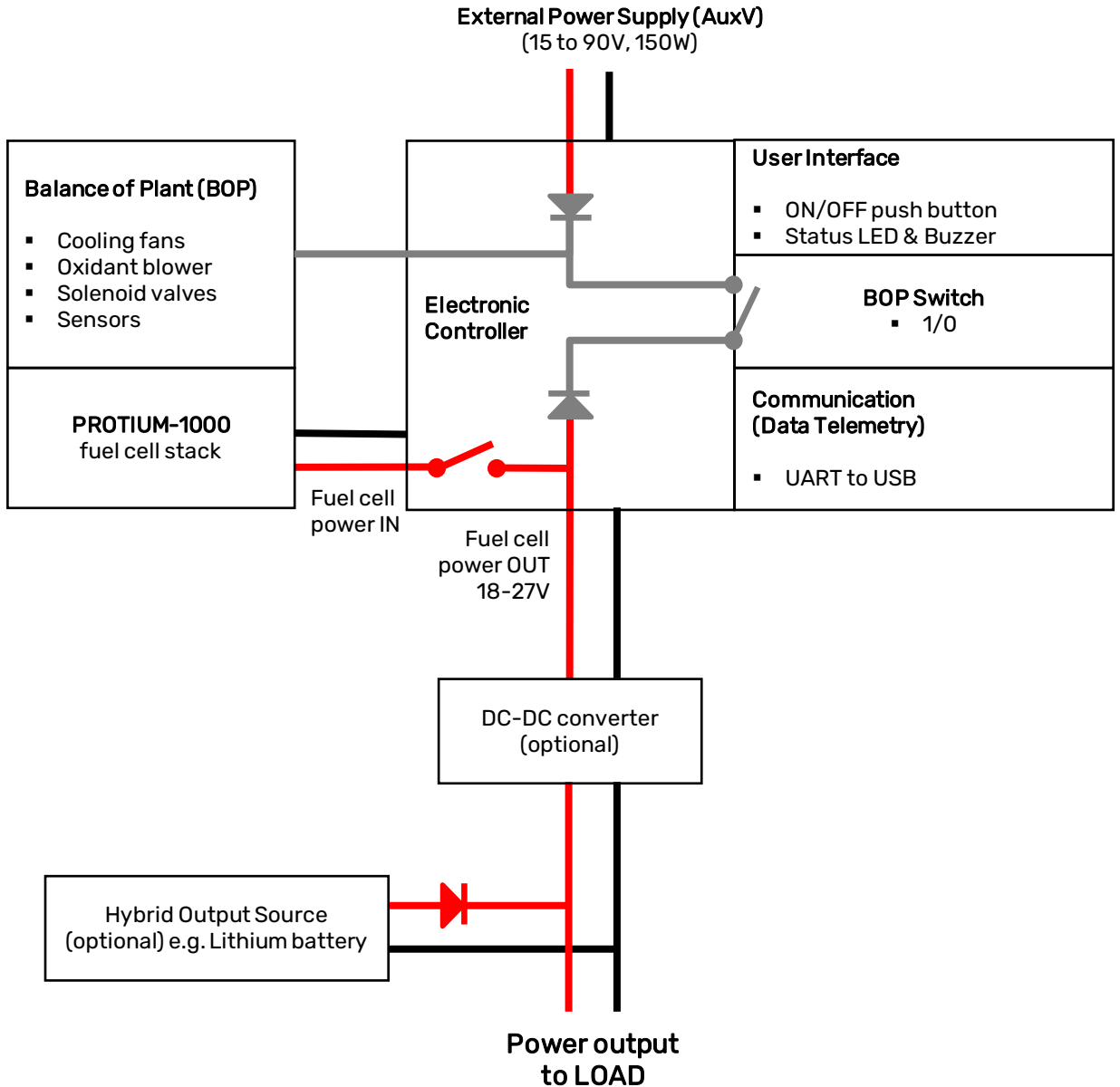

NOTE

1. An external power supply is required to initially turn on the electronic controller.
2. By default, the *BOP Switch* is set to 1. When the system enters **Running Phase** the fuel cell will be able to power its own BOP, if Fuel cell power OUT voltage is higher than External Power Supply voltage. **Tip:** use 15-18V External Power Supply to ensure that it is always lower than the Fuel cell power OUT voltage.
3. By setting the *BOP Switch* to 0, the External Power Supply will power the BOP at all times including during **Running Phase**.

2.4 SYSTEM OPERATION FLOW

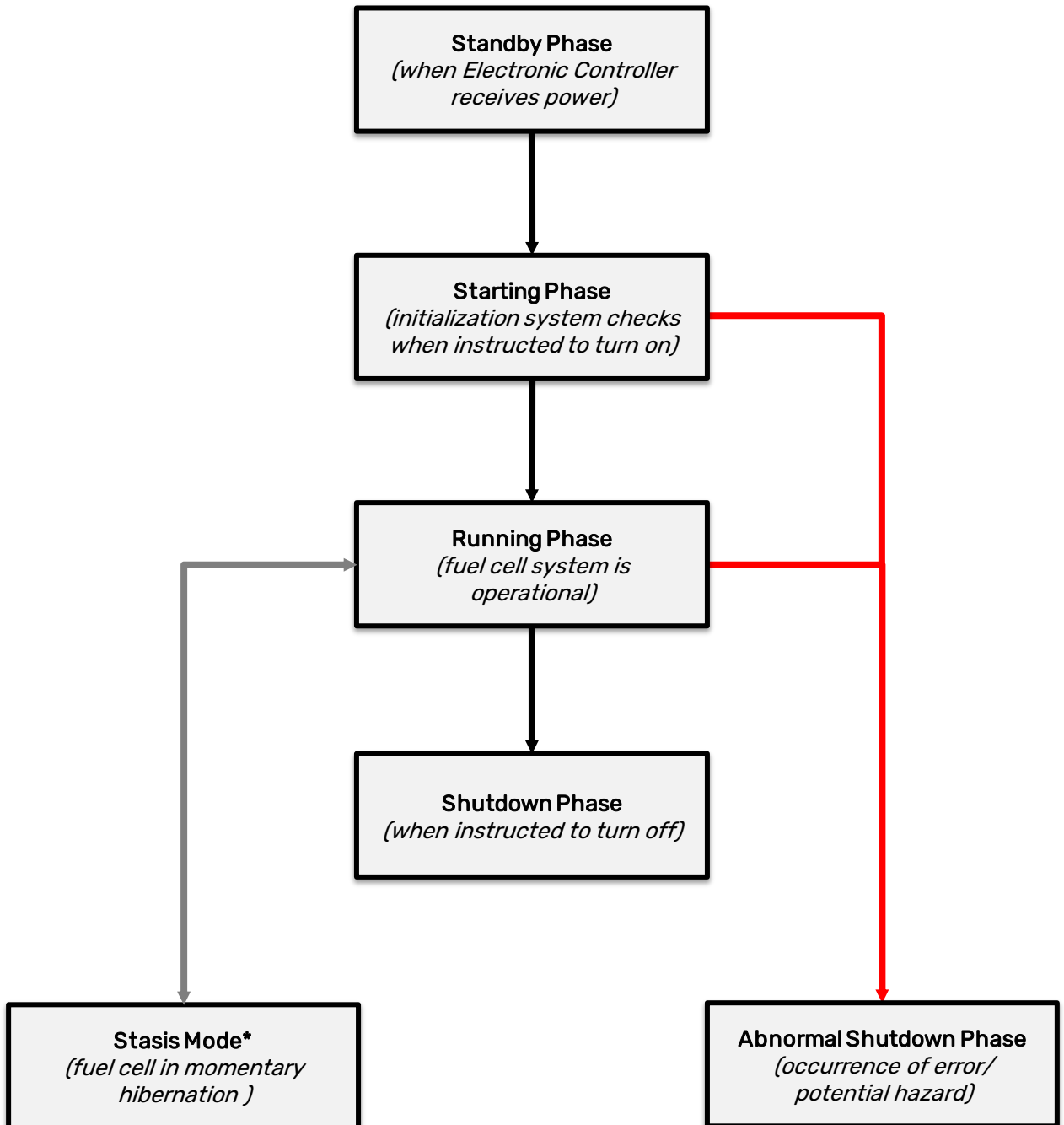

*only with purchase of Spectronik Cerebral-55 Smart DC-DC Converter. Also see Section 3.4.

3 OPERATING PROCEDURES

3.1 SETTING UP PROTIUM-1000

1. Mount PROTIUM-1000 securely in the recommended orientation. Ensure that there is nothing blocking the cooling air inlet in front of the *protective mask (7)*, and sufficient unobstructed clearance from the *oxidant blower (1)* inlet and *cooling fan (10)* outlets.
2. Securely connect a Hydrogen gas purge tubing to the *H2 gas outlet connector (14)*. **Caution:** *channel the purge tubing far away from the oxidant blower inlet.*
3. Connect the *Load connectors (2 and 25)* and the *Free-end wires (24)* to your load. **Tip:** *check that the polarity is correct. It is also advisable to put an ON/OFF switch at your load and ensure that it is turned OFF at this time.*
4. Connect an external power supply (15-90V, 150W) to the *external power supply receptacle (17)* using the supplied *external power supply cable (22 and 23)*. Make sure that the external power supply is OFF at this stage.
5. Connect your Hydrogen gas supply tubing to the *H2 gas inlet connector (21)*. Make sure that your Hydrogen gas supply is OFF at this stage. **Caution:** *ensure that the gas is regulated to 0.5-0.7bar gauge.*

Reminder: ensure that all gas tubing and electrical wire connections are firm and secure.

The setup is now completed and PROTIUM-1000 is ready to be turned on.

3.2 TURNING ON PROTIUM-1000

1. Connect the *Molex connector (27)* to the *Telemetry transmitter port (3)*, and the *USB connector (26)* to a PC. Launch the Spectronik Data Acquisition Graphic User Interface (DAQ GUI) software. Choose the Com Port, set the Baud Rate (57600) and click the S logo. **Tip:** the latest DAQ GUI software and user manual can be downloaded from the PROTIUM-1000 product webpage.
2. Turn on your external power supply and wait for 5s. A welcome message should appear in the GUI. *Status LED (11)* will blink at 10%. Once the Electronic Controller receives power, it will enter **Standby Phase**, awaiting instruction to initiate.
3. Click START. Alternatively, press and hold the *On/Off push button (12)* for more than 2s. PROTIUM-1000 will enter its **Starting Phase** and the message "Low H2 supply" should appear.
4. Turn on your H2 gas supply. **Caution:** *ensure that the gas pressure is regulated to 0.5-0.7bar gauge. Insufficient delivery pressure may cause cell flooding and drop in performance, while excessive pressure may rupture the fuel cell membrane, causing dangerous gas leakage and irreversible cell damage. Ensure that your pressure regulator can provide Hydrogen gas flow rate of more than 15L/min at ≥ 0.5 barg output pressure .*
5. PROTIUM-1000 will do a series of gas purging and internal diagnostic checks. The cooling fans and oxidant blower will turn on. If everything is normal, the system will enter its **Running Phase** - indicated by the message in the GUI and a solid white *Status LED*. All system parameter values can now be seen in the GUI. If there is something wrong, the *Status LED* will flash and error message will appear in the GUI. Follow the basic troubleshooting guide in section 4.
6. Set the *BOP Switch (18)* to 0 or 1 as explained in Section 2.3.

PROTIUM-1000 is now ready to power your application.

NOTES

- Download the DAQ GUI PC app from PROTIUM-1000 product webpage and install it on your PC. Follow the instructions in its user manual. If you do not wish to use the DAQ GUI, you can turn on/off PROTIUM-1000 by using the physical *On-off push button*. However, you will not be able to monitor the performance nor access some functions.
- **Tip:** A good practice is to prepare a gas pressure regulator that can supply 2x PROTIUM-1000's maximum Hydrogen consumption, i.e. around 30L/min at ≥ 0.5 barg.
- Spectronik recommend the [Miniature Gas Pressure Regulator](#) which is designed to be compatible with PROTIUM-1000.

3.3 POWERING YOUR LOAD WITH PROTIUM-1000

1. Turn ON your load and draw power as per normal. **Caution: never pull the fuel cell voltage below 18V or draw power beyond 1000W.**

If Hybrid Output Source (e.g. Lithium battery) is connected at the load, PROTIUM-1000 will provide up to its maximum rated output and the rest is augmented by the battery. The total power available depends on the capacity of the battery. If no battery is connected at the load, the following guideline is recommended:

Mode	Range	Ramp-rate
Constant Voltage Load	Open circuit voltage to 18VDC min or 1000W max	-1VDC/second
Constant Current Load	0A to 55A or 1000W max	+5A/second
Constant Power Load	0W to 1000W max	+100W/second

2. During **Running Phase**, the following live status of the fuel cell can be monitored from the GUI.

Parameters	Description
FC_V	FC voltage (V)
FC_A	FC current (A)
FC_W	FC power (W)
ENERGY	Energy delivered by the fuel cell during this operation (Wh)
FCT1	FC temperature at location 1 (°C)
FCT2	FC temperature at location 2 (°C)
FAN	Cooling fan duty cycle (%)
BLW	Oxidant blower duty cycle (%)
EXIT-IP*	Initiation Point for fuel cell to exit stasis mode (V)
ENTRY-TP*	Termination Point for fuel cell to enter stasis mode (V)
H2P1	H ₂ supply pressure (Barg)
H2P2	H ₂ pressure in FC (Barg)
Tank-P**	Gas tank pressure (Barg)
AuxV	External power supply voltage (V)

* only with purchase of Spectronik Cerebral-55 Smart DC-DC Converter. Also see Section 3.4.

** only with purchase of Spectronik Miniature Gas Pressure Regulator.

3. During **Running Phase**, you may manually control PROTIUM-1000 by clicking commands in the GUI such as Purge, increasing/decreasing oxidant blower speed and cooling fan speed. **Caution: manual control is recommended for advanced users only. For optimal performance, remember to reset to AUTO controls.**

4. During operation, it is normal to see water coming out of the *Cathode outlet duct (9)* and purge tubing. Ensure that water does not drip to any electrical components. **Caution: there might be unreacted Hydrogen gas coming out of the purge tubing. Keep away from fire and electric spark. Ensure sufficient ventilation.**

3.4 RUNNING PROTIUM-1000 IN STASIS MODE

The **Stasis Mode** function allows autonomous transition for PROTIUM-1000 to enter a temporary hibernation. The primary function is to save Hydrogen fuel. The Trigger Points to enter/exit Stasis Mode is purely dependent on the AuxV Voltage.

Stasis Mode is recommended only for advanced users with strong knowledge of Lithium battery and fuel cell hybridization setup including sizing the battery capacity to receive fuel cell charging power.

To ensure user's safety, **Stasis Mode** is currently only available with the purchase of Spectronik Cerebral-55 Smart DC-DC Converter and its accompanying DAQ GUI (PRO) version.

Stasis Mode function can be set active/inactive via the DAQ GUI only during **Standby Phase**. Toggle the STASIS MODE button on/off as desired.

Stasis Mode is restricted by the following conditions:

- System configuration as per the block diagram in Section 3.4 (next page), where Cerebral-55 is connected to the Fuel cell power OUT, providing stable Voltage and Current output to both the Hybrid Output Source and Load.
- System configuration as per the block diagram in Section 3.4 (next page), where the Hybrid Output Source (e.g. Lithium battery) is also the External Power Supply (AuxV) to the Electronic Controller.
- The fuel cell will autonomously enter hibernation when AuxV reaches Termination Point (TP) – defined as the voltage where the battery load is deemed to be full.
- The fuel cell will autonomously exit hibernation when AuxV drops to Initiation Point (IP) – defined as the voltage where the battery load is deemed to be depleted and requires fuel cell recharging.
- The Voltage and Current output limits of Cerebral-55 must be adhered to, and that the product of the Voltage and Current output cannot exceed the fuel cell's rated power output.
- Vset of Cerebral-55 must be higher than TP.

Example of **Stasis Mode** configuration:

- 1
 - Cerebral-55 receives 18-27VDC unregulated input from Fuel cell power OUT.
 - Cerebral-55 output Vset = 50.4VDC.
 - Cerebral-55 output Iset = 19.8A.
 - Therefore the max power out is 1000W to Load and AuxV.

- 2
 - 14S 100Ah LFP battery as both the Hybrid Output Source and AuxV to Electronic Controller.
 - Termination Point (TP) set at 50.4V (when fuel cell will stop recharging battery).
 - Initiation Point (IP) set at 44.8V (when fuel cell will start recharging battery).

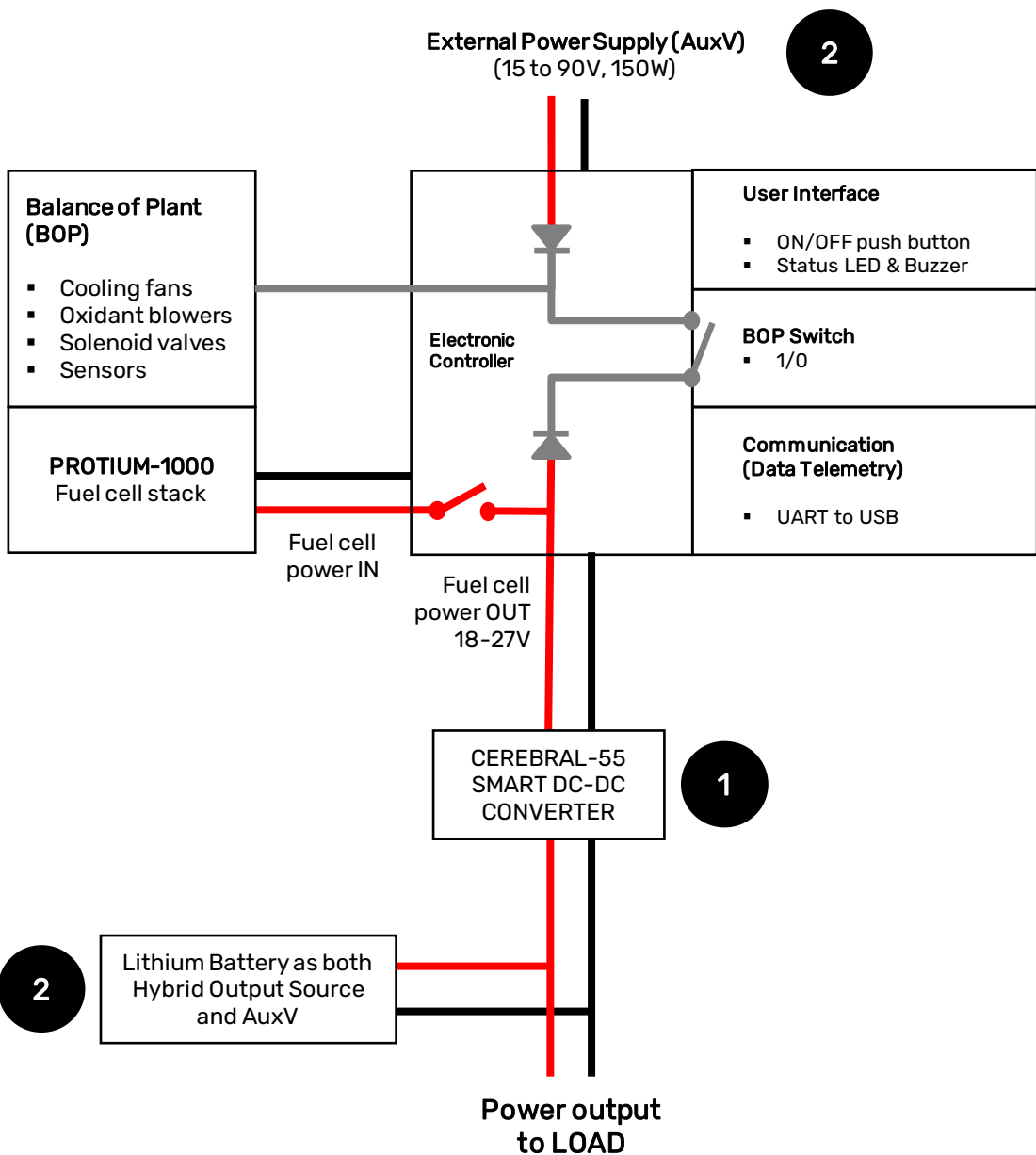

3.5 SHUTTING DOWN PROTIUM-1000

1. Turn OFF your load. The cooling fans will turn faster to cool down the fuel cell, before returning to their minimum speed.
2. In the GUI, click END. Alternatively, press and hold the *On/Off push button* for more than 2s. The message “Shutdown Initiated” will appear in the GUI and PROTIUM-1000 will enter its **Shutdown Phase** by carrying out a series of shutdown procedures such as turning off the gas supply valves, cooling fans and oxidant blower.
3. The message “System OFF” will appear in the GUI. PROTIUM-1000 is now turned off. *Status LED* will blink at 60% on standby awaiting the next start-up command.
4. If you do not intend to restart the system soon, turn OFF your Hydrogen gas supply and remove the Hydrogen gas tubing from the *H2 gas inlet connector*. **Caution: some remaining gas in the tubing will be released into the atmosphere.**
5. Turn OFF the external power supply. All the cables can now be disconnected.

PROTIUM-1000 is now ready to be kept for storage.

4 SYSTEM MONITORING, PROTECTIONS & MANUAL CONTROL

4.1 MANUALLY CONTROLLING THE PROTIUM-1000

The PROTIUM-1000 comes with in-built firmware control that is optimized to bring out its best performance over the applicable ambient environment range. In normal use-case scenario, there is no need for user to fine-tune the parameters. For advanced user who wishes to control the fuel cell manually, the following commands can be entered via the GUI's keyboard function:

Command	PROTIUM-1000 action
start <enter>	Starts the system
end <enter>	Enters normal shutdown phase
ver <enter>	Displays the firmware version
f <enter>	Return to automatic cooling fan control
b <enter>	Return to automatic oxidant blower control
p <enter>	Open the Hydrogen purge valve for 2s. This is useful to remove excess water if cell flooding is suspected due to decreasing power output.
= (equal)	Increase cooling fan speed by 5% (manual control)
- (hyphen)	Decrease cooling fan speed by 5% (manual control)
0	Increase cooling fan speed by 1% (manual control)
9	Decrease cooling fan speed by 1% (manual control)
]	Increase oxidant blower speed by 3% (manual control)
[Decrease oxidant blower speed by 3% (manual control)

Tip: you may also long press the *ON/OFF push button* by >2s to turn ON/OFF the system instead of entering "start" and "end" command via the GUI.

4.2 SYSTEM WARNING & PROTECTIONS

PROTIUM-1000 has several in-built protections. The LED will flash and error message will appear in the GUI. Follow the basic troubleshooting guide below. Most errors should be rectified once the suggested corrective action has been done and the system restarted.

If the error persists, contact hello@spectronik.com.

4.3 SYSTEM WARNING & PROTECTIONS – STARTING PHASE

Warning messages during Starting Phase:

Message	Meaning/ Corrective Action
Gas Tank Not Detected *	Either the gas tank communication cable is not connected or the tank is empty.
Gas Tank Pressure Low *	There is less than 20 Bar remaining in the gas tank.
Gas Tank Insufficient Pressure *◎	There is not enough pressure in the gas tank to start.
Low H2 Supply	Hydrogen supply pressure is low and the system will wait up to 1min for correction. Please check and correct the delivery pressure.
Error: Low H2 Supply ◎	Hydrogen is not correctly supplied within the stipulated time limit. Check and ensure sufficient Hydrogen supply and correct delivery pressure. Restart the system.
Over Pressure	Hydrogen supply pressure is too high and the system will wait for 1min. Reduce the delivery pressure.
Error: Over Pressure ◎	Hydrogen is not properly supplied within the stipulated time limit. Check and ensure sufficient Hydrogen supply and correct delivery pressure. Restart the system.
High Temperature	Stack temperature is too high and the system will wait for 1min.
Error: High Temperature ◎	Disconnect everything and wait for system to cool down and restart after 10min. If the problem persists, internal temperature sensor might have been compromised. Contact Spectronik.
Error: FC Over Cooled ◎	Stack temperature is too low. Wait for ambient temperature to increase and restart the system.
FC Sealing Compromised ◎	Possible stack leakage. Check and ensure all gas tubing and connectors are securely connected.
Error: Low Voltage ◎	Stack open circuit voltage is too low. Check and ensure sufficient hydrogen supply and correct delivery pressure. Restart after 1 min.
Purge Valve Error ◎	The Purge Valves might not be activating. If the environment is cold, try heating it up.
Supply Valve Error ◎	The Supply Valves might not be activating. If the environment is cold, try heating it up.
Gas Tank Outlet is Leaking *◎	There has been an unwarranted pressure drop between Gas Tank and Supply Valves. Please verify gas line connections.
◎ <i>Emergency Shutdown = Abnormal Shutdown Phase would be activated</i>	
* <i>with purchase of Spectronik Miniature Gas Pressure Regulator</i>	

4.4 SYSTEM WARNING & PROTECTIONS – RUNNING PHASE

Warning messages during Running Phase:

Message	Meaning/ Corrective Action
High Temperature ●	Stack temperature is too high. The fuel cell power output to load will be temporarily disconnected for 5s for system to recover. LED will blink. Reduce your load.
Error: High Temperature ●	Stack temperature is too high. Disconnect everything and wait for system to cool down and restart after 10min. If the problem persists, internal temperature sensor might have been compromised. Contact Spectronik.
Low Temperature ●	Stack temperature is low. LED will blink.
Error: FC Over Cooled ●	Stack temperature is too low for operation.
Low Voltage ●	Stack Voltage at minimum threshold of 0.6V/cell.
Error: Low Voltage ●	Stack Voltage below safety threshold limit.
Low H2 Supply ●	Hydrogen supply pressure is low and the fuel cell power output to load will be temporarily disconnected. LED will blink. Check and ensure sufficient Hydrogen supply and correct delivery pressure.
Error: Low H2 Supply ●	Hydrogen supply pressure is too low. Check and ensure sufficient Hydrogen supply and correct delivery pressure. Restart the system.
High H2 Supply Pressure ●	Hydrogen supply pressure is too high and the supply valve will be temporarily shut off. Reduce the delivery pressure.
Error: High H2 Supply Pressure ●	Hydrogen supply pressure is too high. Check and ensure sufficient Hydrogen supply and correct delivery pressure. Restart the system.
Low AuxV ●	The External Power Supply is at below 15V.
Gas Tank Running Low *●	The pressure in the gas tank is below 20 Bar.
Gas Tank Depleting *●	The pressure in the gas tank is below 10 Bar.
<p>● <i>Emergency Shutdown = Abnormal Shutdown Phase would be activated</i></p> <p>● <i>Status LED flashing at 80% to alert warning during Running Phase</i></p> <p>* <i>with purchase of Spectronik Miniature Gas Pressure Regulator</i></p>	

4.5 SYSTEM WARNING & PROTECTIONS – LED STATUS & OTHER MESSAGES

LED Status:

Phase	Blink % (at 1Hz)	Meaning
Power ON/ Standby Phase	10%	5s after start-up power is provided into the Electronic Controller, LED will blink at 10%, indicating that the system is ready to receive its “start” command
Starting Phase	40%	Executing Starting Phase procedures
Running Phase	100%	System in normal Running Phase
Running Phase	80%	System warning during Running Phase
After shutdown	60%	System off due to normal shutdown and on standby for the next “start” command
Abnormal Shutdown Phase	0%	System off due to abnormal shutdown

Other messages:

Message	Meaning
Fan PWM auto	Cooling fans control is in auto mode
Fan PWM manual	User has manually changed the fan setting
Blower auto	Blower control is in auto mode
Blower manual	User has manually changed the blower setting
Mileage	Cumulative Watt-Hour of the system
Shutdown Initiated	Entering normal Shutdown Phase
Abnormal Shutdown Initiated	Entering Abnormal Shutdown Phase due to an error
System off	System is turned off and ready to restart at the next command
Battery reached set point, system entered stasis mode	AuxV reached Termination Point (TP) voltage and fuel cell enters Stasis Mode
Running in Stasis Mode	Fuel cell is in Stasis Mode

5 MAINTENANCE AND STORAGE

5.1 MAINTENANCE FOR PROTIUM-1000

When not in use, Spectronik recommends that PROTIUM-1000 is reconditioned at least once a month.

1. Set up PROTIUM-1000 as per instructions in Section 3, using a DC electronic load in lieu of your regular load.
2. After the system enters “Running Phase”, set constant voltage (CV) load of 18V and run the system for 1h. The fuel cell should recover to its maximum rated power output.

PROTIUM-1000 is now ready for usual operation or can be stored again for future use.

5.2 STORAGE

Keep PROTIUM-1000 in an open, cool (standard room temperature of 25°C) and dry place.