



PROTIUM-2500

FUEL CELL SYSTEM

USER GUIDE

SAFETY, HANDLING & SUPPORT

WARNING:

Failure to follow these safety instructions could result in fire, electric shock, other injuries, or damage to PROTIUM-2500 Fuel Cell System (PROTIUM-2500) or other property. Read all the safety information below before using PROTIUM-2500.

Handling Handle PROTIUM-2500 with care. It is made of thin sheet metal, graphite, and plastic and has sensitive electrochemical membrane and components inside. PROTIUM-2500 is not designed for extreme conditions, rough handling, vibration, shock or drop. Keep PROTIUM-2500 away from heat, flame, strong sunlight, water, dust, soil or mud. Do not use a damaged PROTIUM-2500.

Repairing PROTIUM-2500 is assembled under high compression. Do not disassemble or tamper with PROTIUM-2500. Do not troubleshoot, repair or replace any component by yourself.

Hydrogen Use only high purity (99.999%) dry Hydrogen gas with PROTIUM-2500. Hydrogen is a colorless, odorless and highly flammable gas. It is non-toxic but can cause asphyxiation. Follow all local rules and regulations for safe handling, storage and usage of Hydrogen gas. Do not smoke when operating PROTIUM-2500.

Ventilation Operate PROTIUM-2500 in a well ventilated environment. Fresh air intake for the fuel cell oxidant blower, cooling air entry from the front of the protective mask, and hot air exit from the cooling fans shall not be obstructed or restricted.

Purging PROTIUM-2500 periodically flushes its anode during operation, releasing Hydrogen gas and water from the Hydrogen gas outlet. Do not block the Hydrogen gas outlet. Do not bring flame or electric spark close to the Hydrogen gas outlet. It is advisable to attach a longer gas tubing to the Hydrogen gas outlet connector and safely guide the purge exhaust far away from the fuel cell.

CAUTION: *always put the Hydrogen gas outlet tubing behind the cooling fan and never in front of the fuel cell stack. Purged Hydrogen mixed with air intake into the fuel cell's cathode channels may cause fire and irreversible damage to the fuel cell.*

Connectors, ports and buttons Never force a connector into a port or apply excessive pressure to a button. If the connector and port do not join with reasonable ease, they probably do not match. Check for obstructions and ensure that the connector matches the correct port.

Disposal and recycling As PROTIUM-2500 contains electronic components, it must be disposed of separately from household waste. When PROTIUM-2500 reaches its end of life, follow local laws and regulations for proper disposal and recycling options.

High-consequence activities PROTIUM-2500 is a customized system with pending safety tests and certifications. It is not intended for use where the failure of the system could lead to death, personal injury or severe environmental damage.

Disclaimer Every effort has been made to ensure that the information in this manual is accurate. This manual serves to adequately recommend safe operating procedures, but shall not be treated as comprehensive. Do not use PROTIUM-2500 in any other way than the one recommended in this manual. Spectronik reserves the right to change system specifications, appearance or discontinue the product at any time.

Warranty Spectronik warrants the included hardware product and accessories against defects in materials and workmanship for the first 30 days after delivery. Spectronik does not warrant against normal wear and tear, nor damage caused by accident or abuse.

To obtain service, contact support@spectronik.com

1 OVERVIEW

1.1 PROTIUM-2500 SYSTEM OVERVIEW

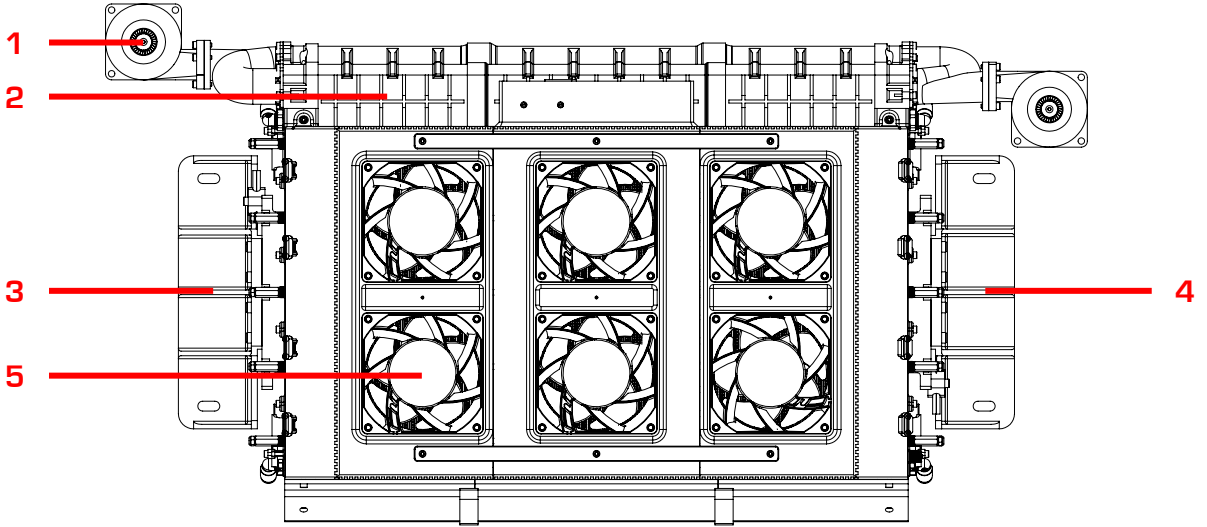

Figure 1.1.1 Top view of PROTIUM-2500

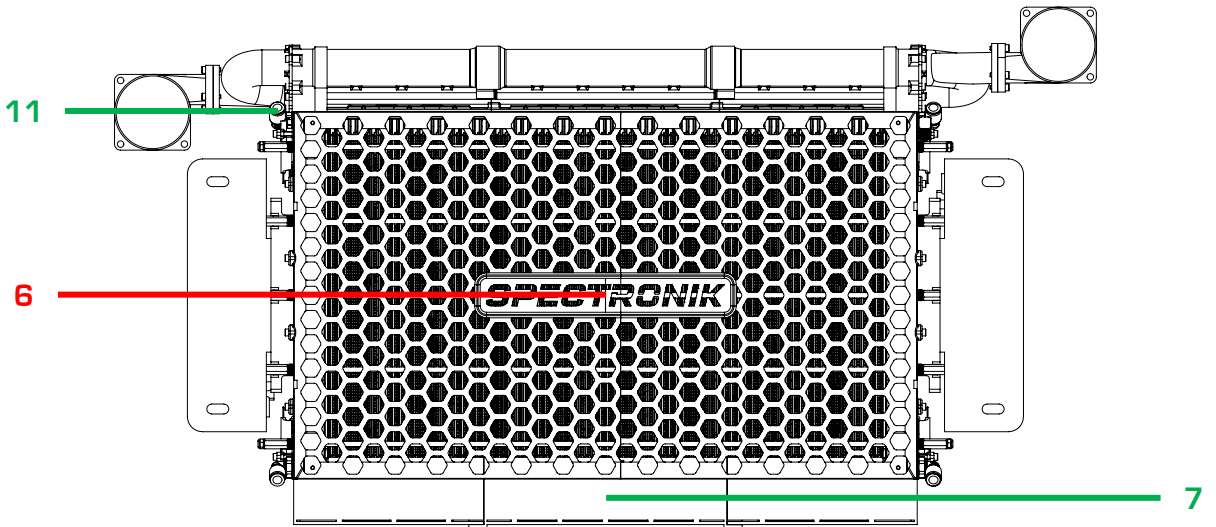

Figure 1.1.2 Bottom view of PROTIUM-2500

ITEM DESCRIPTION

- | | | | |
|----|------------------------|----|---------------------|
| 1. | Oxidant blower [x2] | 5. | Cooling fan [x6] |
| 2. | Oxidant flow manifold | 6. | Protective mask |
| 3. | Mounting plate (left) | 7. | Cathode outlet duct |
| 4. | Mounting plate (right) | | |

1.1 PROTIUM-2500 SYSTEM OVERVIEW

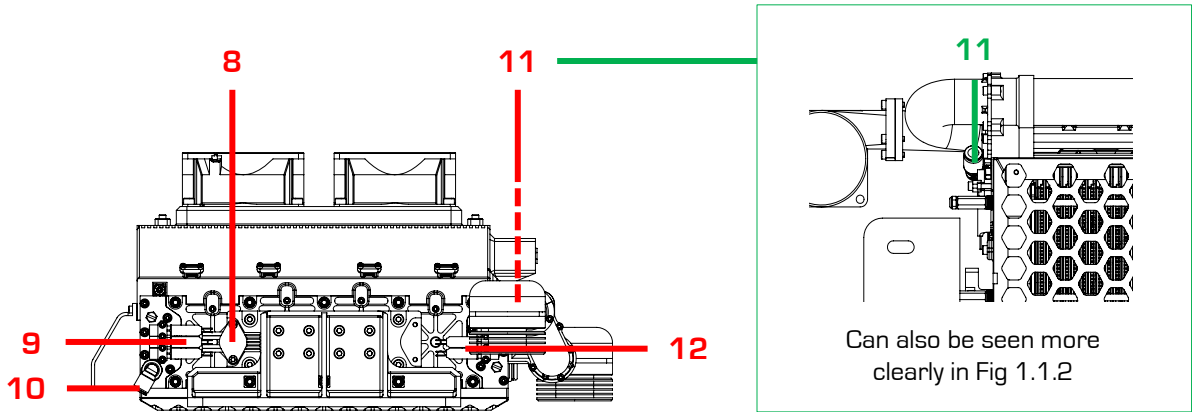

Figure 1.1.3 Right view of PROTIUM-2500

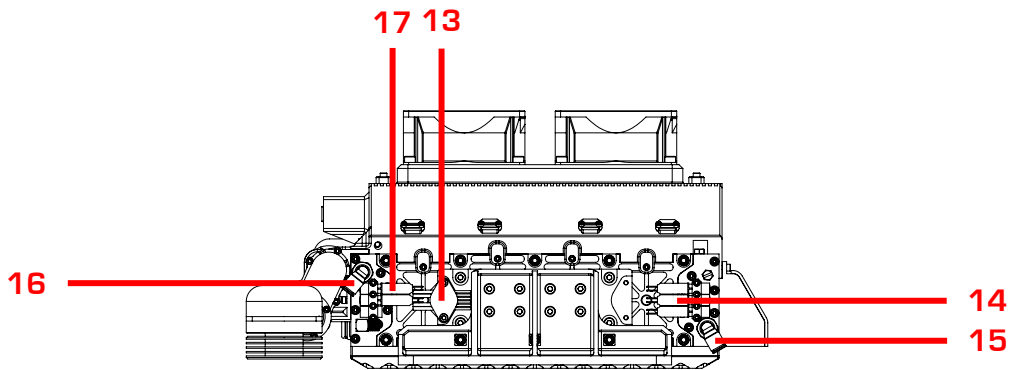

Figure 1.1.4 Left view of PROTIUM-2500

ITEM DESCRIPTION

8.	Gas pressure sensor 1	13.	Gas pressure sensor 2
9.	H2 supply valves (right)	14.	H2 supply valves (left)
10.	H2 gas inlet connector (right)	15.	H2 gas inlet connector (left)
11.	H2 gas outlet connector (right)	16.	H2 gas outlet connector (left)
12.	H2 purge valves (right)	17.	H2 purge valves (left)

1.1 PROTIUM-2500 SYSTEM OVERVIEW

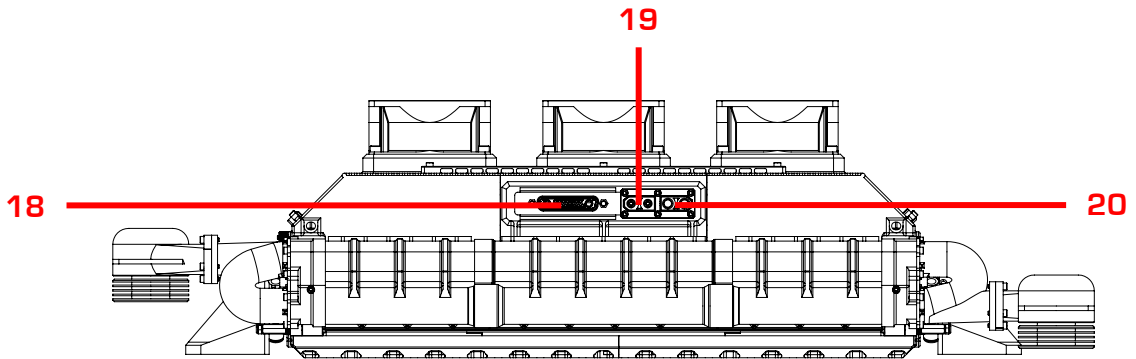

Figure 1.1.5 Front view of PROTIUM-2500

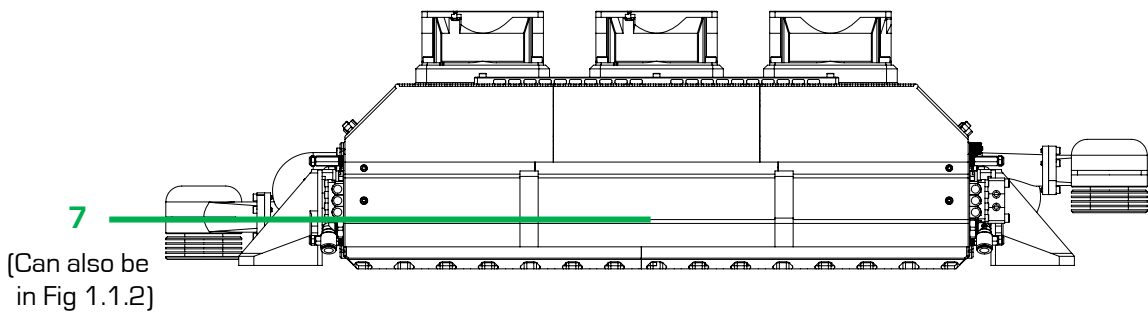

Figure 1.1.6 Back view of PROTIUM-2500

ITEM DESCRIPTION

- | | | | |
|-----|--------------------------|-----|--------------------------|
| 18. | Power/Signal receptacle | 20. | Stack power output [-ve] |
| 19. | Stack power output [+ve] | | |

1.2 ELECTRONIC CONTROLLER

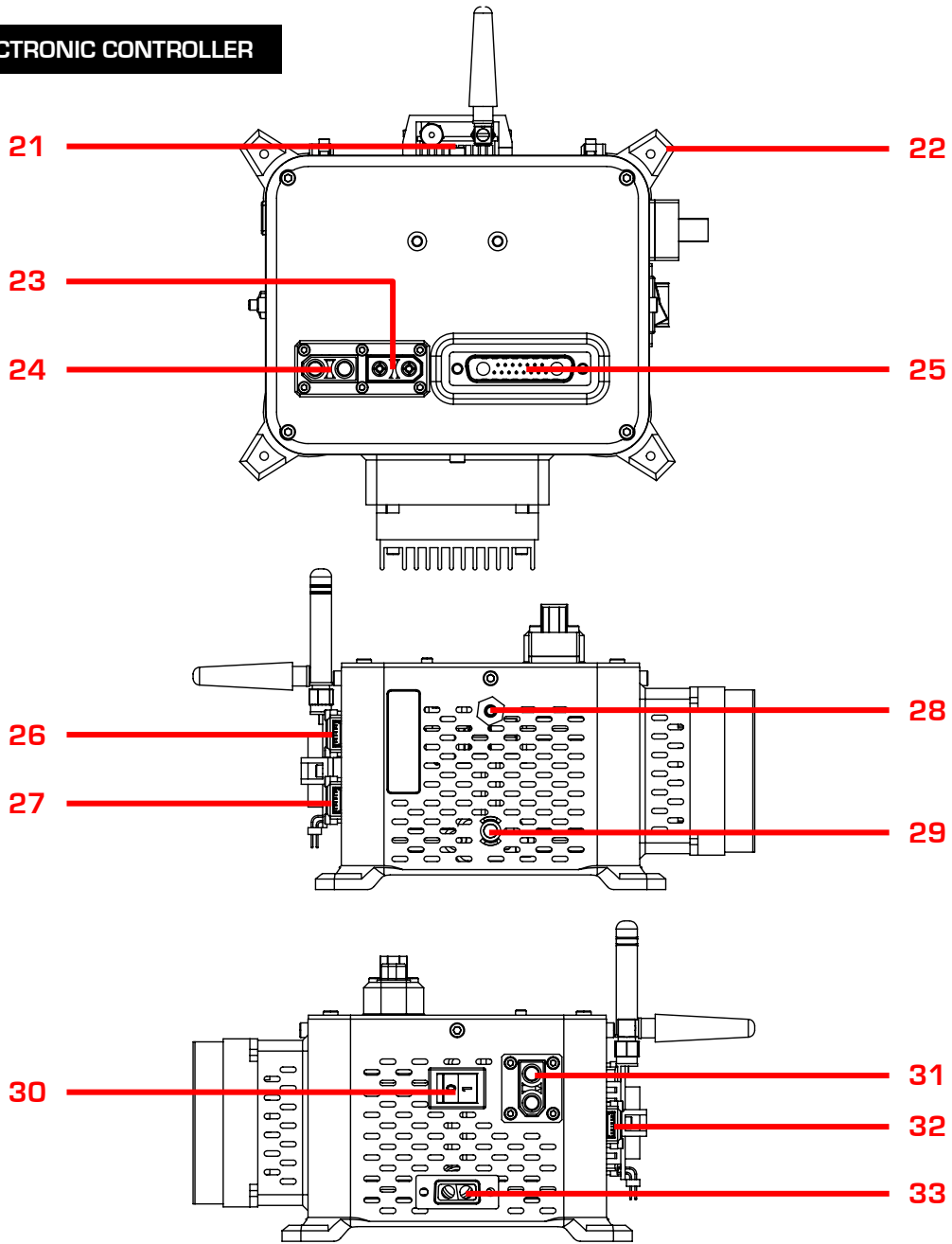

Figure 1.2.1 Top, Left and Right views of Electronic Controller

ITEM DESCRIPTION

21.	Radio telemetry transmitter	28.	On/Off push button
22.	Mounting hole (x4)	29.	Status LED
23.	Stack power output (+ve)	30.	Balance-of-plant (BOP) switch
24.	Stack power output (-ve)	31.	Load connector (XT-90 female)
25.	Power/Signal header	32.	Telemetry transmitter port
26.	Programming port	33.	External power supply receptacle
27.	P2 sensor port		

1.3 STANDARD ACCESSORIES

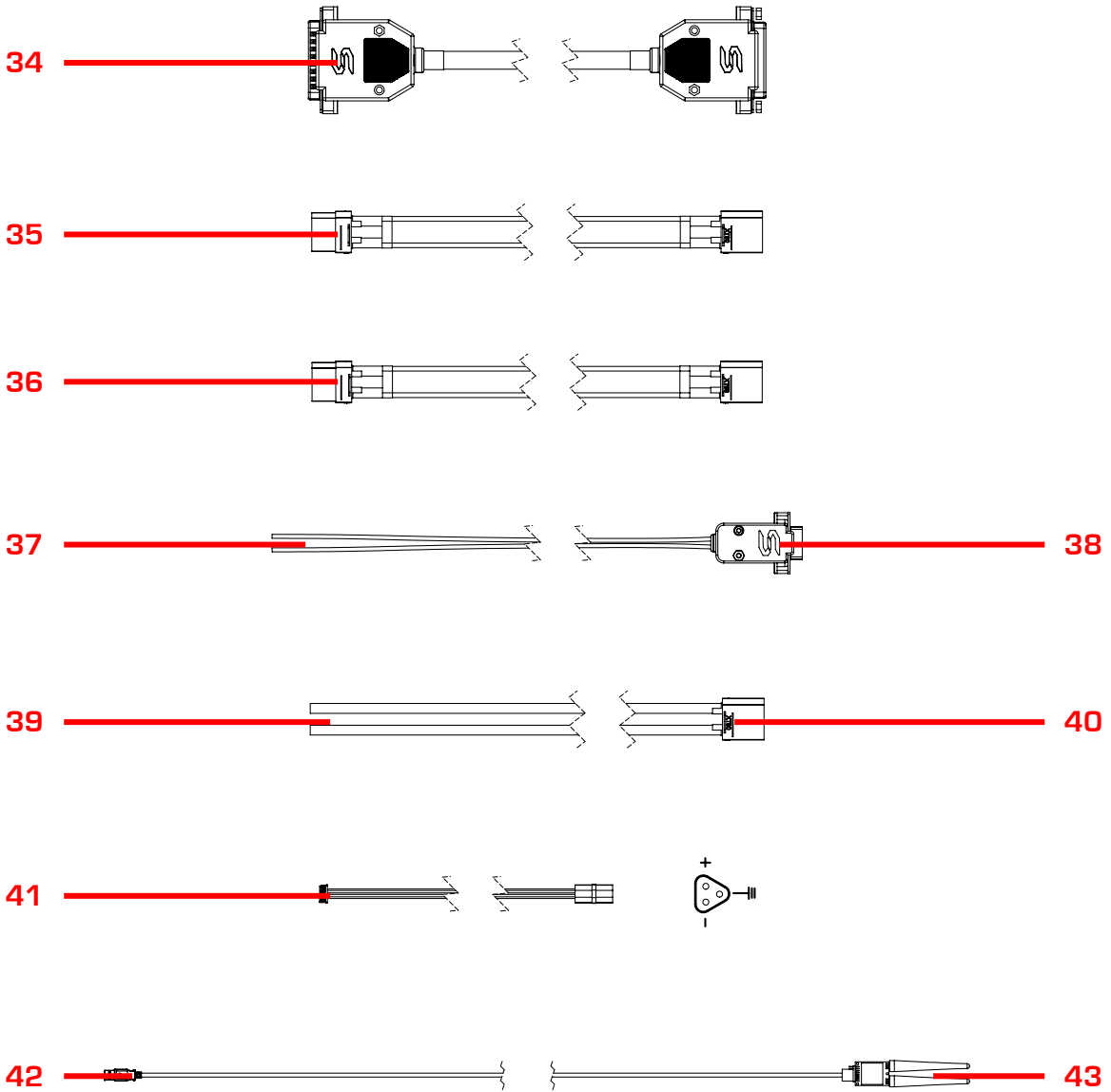
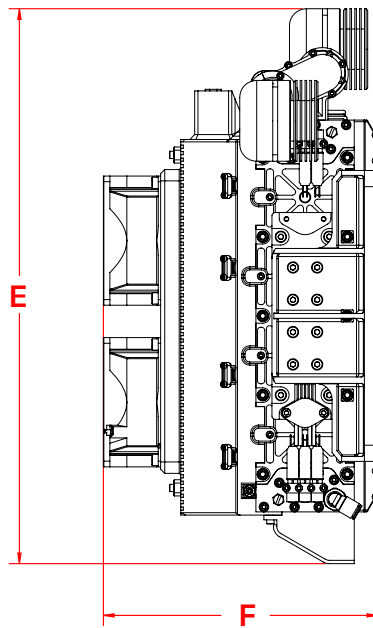
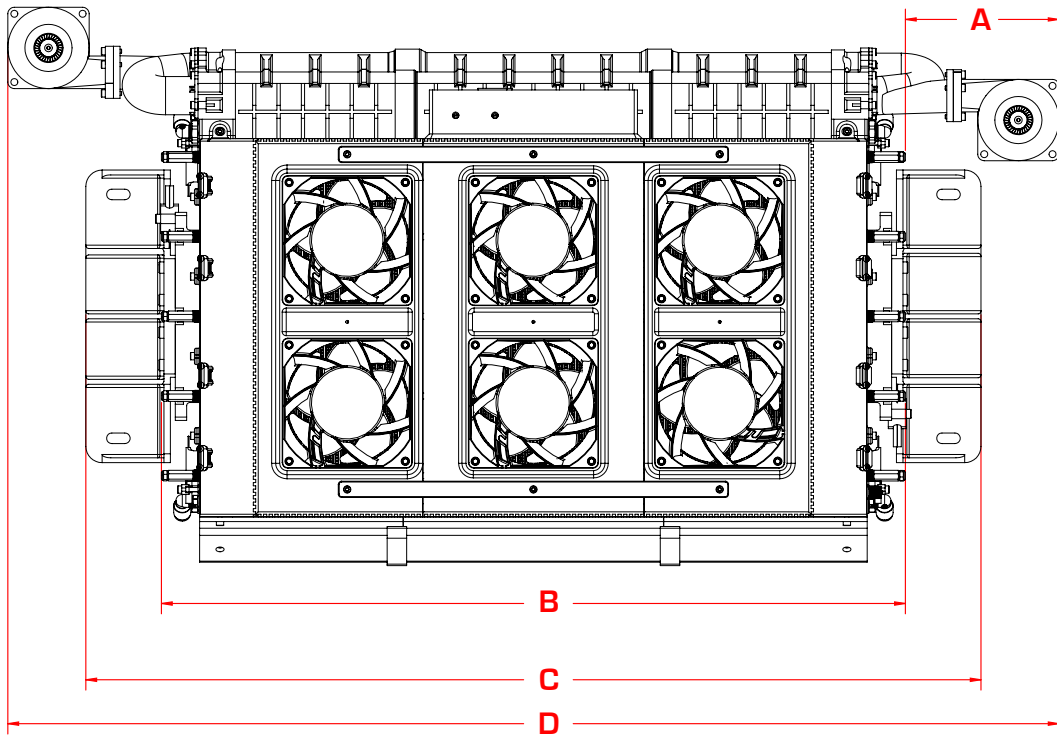

Figure 1.3.1 Accessories

ITEM DESCRIPTION

34. Power/Signal extension cable	39. Free-end wires for user's load
35. Stack power output (+ve) extension cable	40. Load connector (XT-90 male)
36. Stack power output (-ve) extension cable	41. P2 sensor cable
37. Free-end wires for user's power supply	42. USB connection to PC
38. External power supply header	43. Radio modem receiver

1.4 MECHANICAL DIMENSIONS - PROTIUM-2500



All dimensions in mm

A	94.50	D	646.60
B	457.60	E	343.50
C	550.60	F	170.00

1.5 MECHANICAL DIMENSIONS – ELECTRIC CONTROLLER

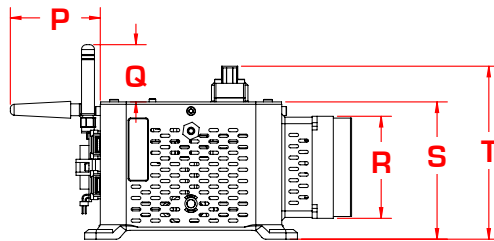
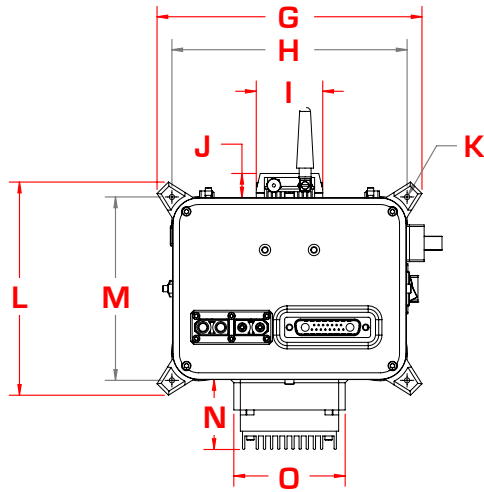

All dimensions in mm

G	163.40	L	131.40	Q	35.40
H	145.00	M	113.00	R	63.20
I	41.00	N	43.10	S	85.00
J	15.00	O	68.60	T	107.10
K	∅ 3.20 (4x)	P	55.60		

1.6 MECHANICAL DIMENSIONS – STANDARD ACCESSORIES

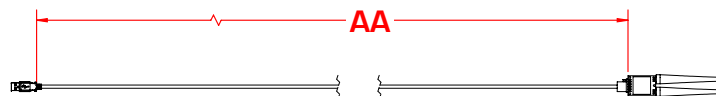
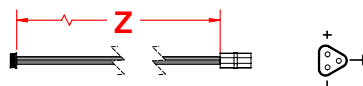
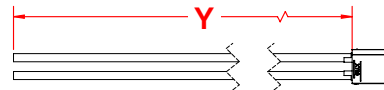
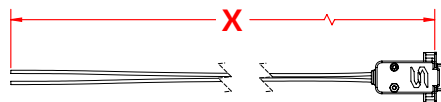
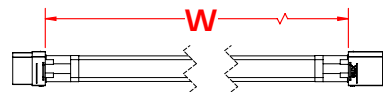
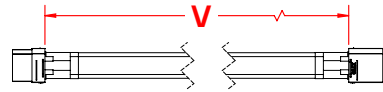
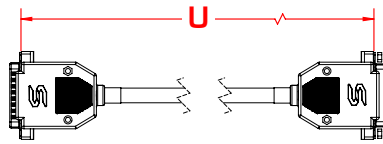

All dimensions in mm

U	1000.00	Y	1000.00
V	1000.00	Z	600.00
W	1000.00	AA	1800.00
X	1000.00		

1.7 MOUNTING AND AIR CLEARANCE

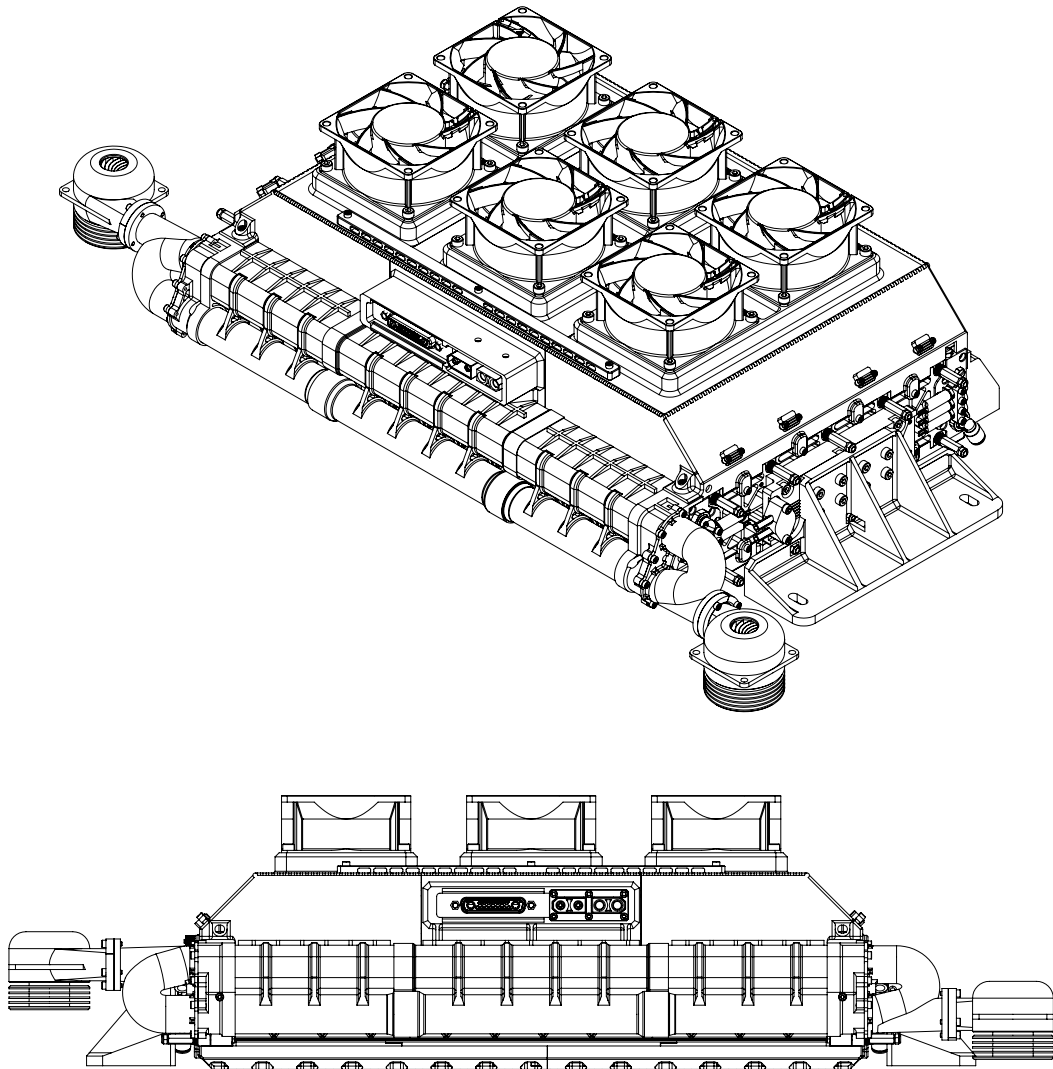

Figure 1.7.1 Recommended orientation of PROTIUM-2500

PROTIUM-2500 cannot be mounted in any orientation due to internal routings of the gas streams within the fuel cell stack. The stack should also be level to ensure water does not get trapped in the Cathode channels, obstructing the oxidant flow and causing potential performance drop and cell damage. Mount PROTIUM-2500 horizontally in the recommended orientation above, with the protective mask facing downwards and the cooling fans facing upwards.

For optimal oxidant and cooling airflows, it is also recommended that there is **at least 15cm unobstructed clearance from the protective mask and oxidant blower inlet**, and **30cm unobstructed clearance from the cooling fans' outlet**.

1.8 MECHANICAL DIMENSION – MOUNTING AND CLEARANCE

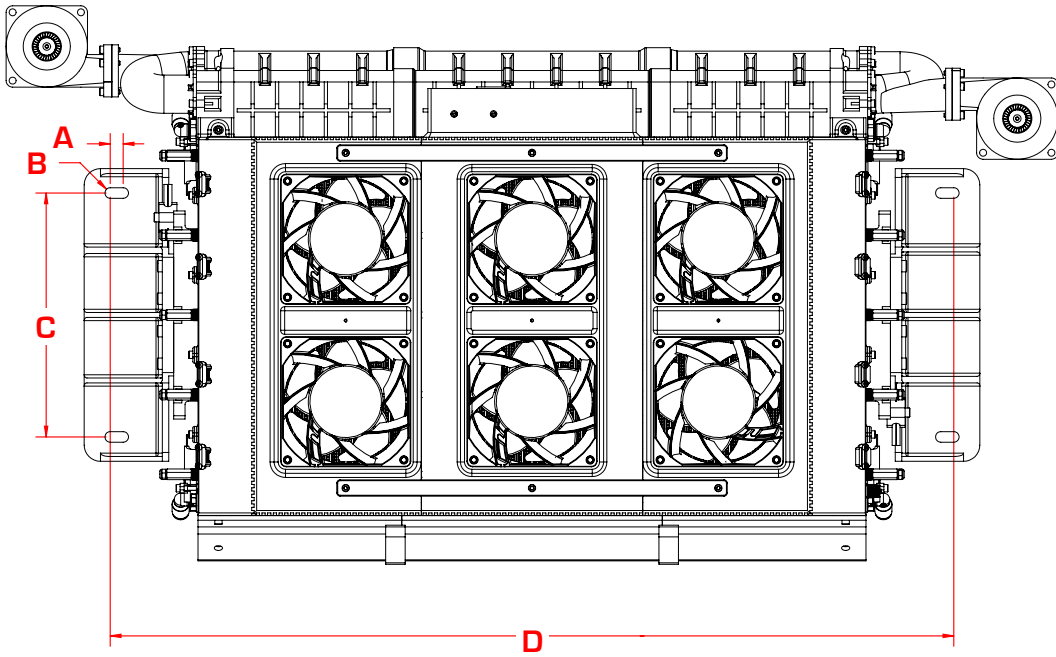

Figure 1.8.1 Dimensions of the mounting holes

All dimensions in mm

A	8.00	C	150.00
B	R3.25	D	510.60 (centre to centre)

2 SPECIFICATIONS

2.1 PROTIUM-2500 TECHNICAL DATA SHEET

Fuel cell	
Type	PEM
No. of cells	80
Architecture	Closed cathode
Coolant	Air cooled
Rated/gross power	2500/3000W
Rated/gross current	52.5/62.5A
Voltage output	48-72VDC
Start-up time	30s
Operating ambient temp.	[-10,45]°C
Operating altitude without power derating	1500m AGL
System weight	9,800g
Max dimension	647 x 344 x 170mm
Fuel supply	
Hydrogen gas	Dry, 99.999% purity
Delivery pressure	0.7bar (10 psig)
Fuel consumption @ rated power	31.5L/ min
Gas tubing	PU, 8 x 5.5
Supply & purge control	Solenoid valves with integrated pressure sensor
Stack leakage checks	Automated via integrated pressure sensors
Electronic controller	
Processor board	FEATHER V1.2
Weight (including casing)	810g
Output connector	XT-90
Warning & protections	Low voltage, high/low temperature, high/low pressure, low battery, stack leakage
Communication	868MHz ultra long range radio modem
Data acquisition (DAQ) software	PC GUI/ Android app
Remote control	Fan speed, blower speed, manual purge, remote on-off

2.2 VI CURVE

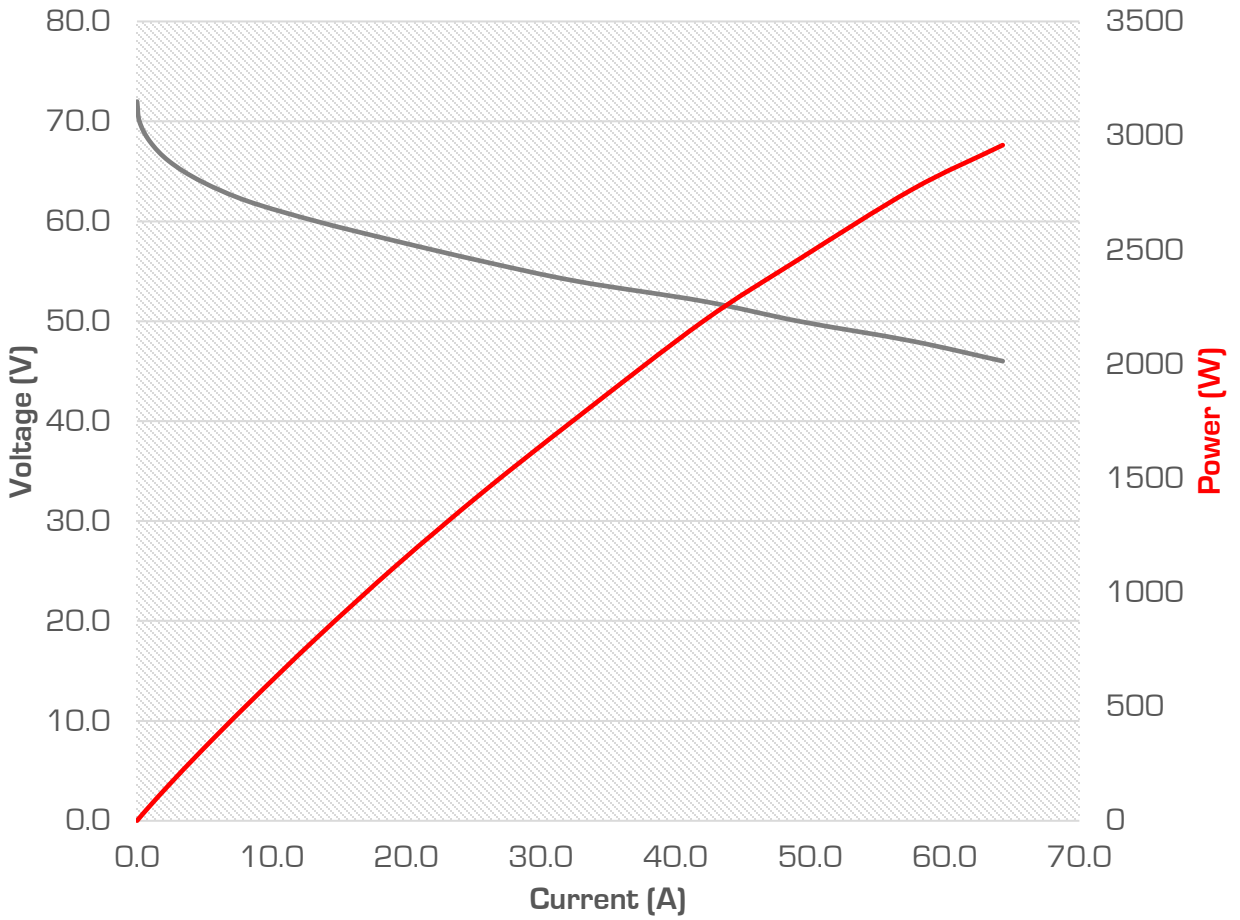
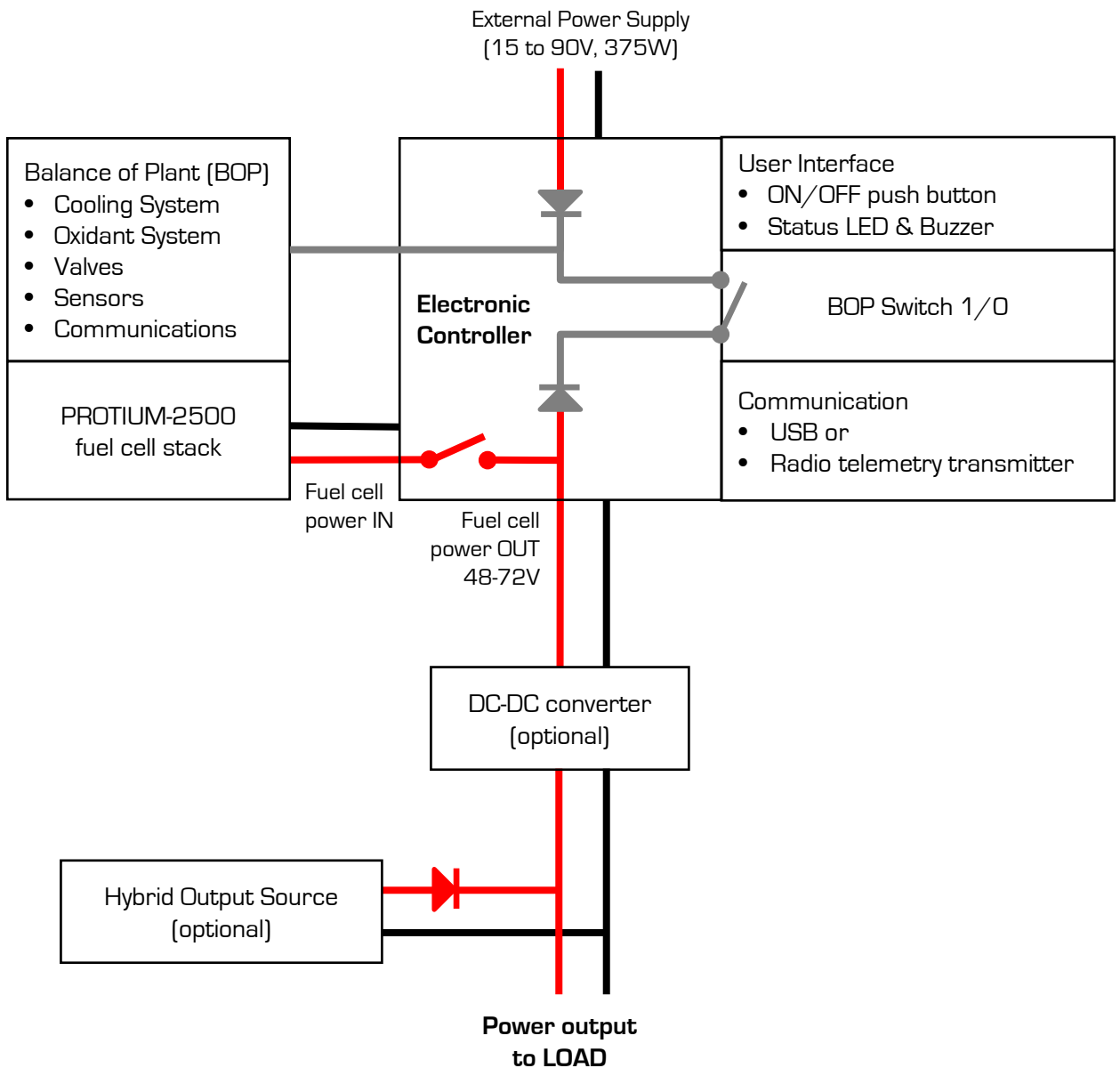

Figure 2.2.1 Nominal polarization curve for a fully conditioned PROTIUM-2500 at its Beginning-of-Life (BOL).

TEST CONDITIONS

- Ambient temperature: 24°C
- Relative humidity: 60%
- H₂ supply pressure: 10psig
- Dead-ended operation
- Balance-of-plant (BOP) powered by fuel cell
- T_{cell} at 2500W: 66°C

2.3 SYSTEM BLOCK DIAGRAM



NOTE

1. An external power supply is required to initially turn on the electronic controller.
2. By default, the *BOP Switch* is set to 1. When the system enters “Running Phase” the fuel cell will be able to power its own BOP, **if Fuel cell power OUT voltage is higher than External Power Supply voltage**. **Tip:** use 15-48V External Power Supply to ensure that it is always lower than the Fuel cell power OUT voltage.
3. By setting the *BOP Switch* to 0, the External Power Supply will power the BOP at all times including “Running Phase”.

3 OPERATING PROCEDURES

3.1 SETTING UP PROTIUM-2500

1. Mount PROTIUM-2500 securely in the recommended orientation. Ensure that there is nothing blocking the cooling air inlet below the *protective mask (6)*, and sufficient unobstructed clearance from the *oxidant blower (2)* inlets and *cooling fans (5)* outlet.
2. There are two Hydrogen gas purge tubing left and right of the fuel cell stack. Ensure that they are securely connected to the *H₂ gas outlet connectors (11) and (16)*. *Caution: channel the purge tubing far away from the oxidant blower (2) inlets.*
3. Connect PROTIUM-2500 to the Electronic Controller using the *Power/Signal (34)*, *Stack power output (+ve) (35)* and *Stack power output (-ve) (36)* extension cables. Also connect the *P2 sensor cable (41)* from PROTIUM-2500 to the *P2 sensor port (27)*.
4. Connect the *Load connectors (31 and 40)* and the *Free-end wires (39)* to your load. *Tip: check that the polarity is correct. It is also advisable to put an ON/OFF switch at your load and ensure that it is turned OFF at this time.*
5. Connect an external power supply [15-90V, 375W] to the *external power supply receptacle (33)* using the supplied *external power supply cable (37 and 38)*. Make sure that the external power supply is OFF at this stage.
6. PROTIUM-2500 has two *H₂ gas inlet connectors (10 and 15)*. Connect your Hydrogen gas supply to both inlets. Make sure that your Hydrogen gas supply is OFF at this stage. *Caution: ensure that the gas is regulated to 0.5-0.7bar gauge.*

Reminder: ensure that all gas tubing and electrical wire connections are firm and secure.

The setup is now completed and PROTIUM-2500 is ready to be turned on.

3.2 TURNING ON PROTIUM-2500

1. Connect the *Radio modem receiver (43)* to a PC via *the USB cable (42)*. Launch the Spectronik Data Acquisition Graphic User Interface (DAQ GUI) software. Choose the Com Port, set the Baud Rate (57600) and click the S logo. *Tip: the latest DAQ GUI software and user manual can be downloaded from the PROTIUM-2500 product webpage.*
2. Turn on your external power supply and wait for 5s. A welcome message should appear in the GUI. *Status LED (29)* will blink at 10%.
3. Click START. The message <Low H2 Supply> should appear.
4. Turn on your H2 gas supply. *Caution: ensure that the gas pressure is regulated to 0.5-0.7bar gauge. Insufficient delivery pressure may cause cell flooding and drop in performance, while excessive pressure may rupture the fuel cell membrane, causing dangerous gas leakage and irreversible cell damage. Ensure that your pressure regulator can provide Hydrogen gas flow rate of more than 35L/min.*
5. PROTIUM-2500 will do a series of gas purging and internal diagnostic checks. The cooling fans and oxidant blowers will turn on. If everything is normal, the system will enter its “Running Phase” – indicated by the message in the GUI and a solid white Status LED. All system parameter values can now be seen in the GUI.
6. Set the *BOP Switch (30)* to 0 or 1 as explained in Section 2.3.

PROTIUM-2500 is now ready to power your application.

3.3 POWERING YOUR LOAD WITH PROTIUM-2500

1. Turn ON your load and draw power as per normal. **Caution: never pull the fuel cell voltage below 48V or draw power beyond 2500W.**

If hybrid battery is connected at the load, PROTIUM-2500 will provide up to its maximum rated output and the rest is augmented by the battery. The total power available depends on the capacity of the battery. If no hybrid battery is connected at the load, the following guideline is recommended:

Mode	Range	Ramp-rate
Constant Voltage Load	Open circuit voltage to 48VDC min or 2500W max	-1VDC/second
Constant Current Load	0A to 55A or 2500W max	+2A/second
Constant Power Load	0W to 2500W max	+100W/second

2. During Running Phase, the following live status of the fuel cell can be monitored from the GUI.

Parameters	Description
FCV	FC voltage [V]
FCA	FC current [A]
FCW	FC power [W]
Energy	Energy delivered by the fuel cell during this operation [Wh]
FCT1	FC temperature at location 1 [° C]
FCT2	FC temperature at location 2 [° C]
FAN	Cooling fan duty cycle [%]
BLW	Oxidant blower duty cycle [%]
H2P1	H ₂ supply pressure [Barg]
H2P2	H ₂ pressure in FC [Barg]
Tank-P*	Gas tank pressure [Barg]
Tank-T*	Gas tank temperature [° C]
DCDCV*	Converter voltage [V]
DCDCA*	Converter current [A]
DCDCW*	Converter power [W]
BattV	External power supply voltage [V]

*with purchase of optional Spectronik accessories (gas tank, pressure regulator and DC/DC converter)

3. During Running Phase, you may manually control PROTIUM-2500 by clicking commands in the GUI such as Purge, increasing/decreasing oxidant blower speed and cooling fans speed. **Caution: manual control is recommended for advanced users only. For optimal performance, remember to reset to AUTO controls.**

4. During operation, it is normal to see water coming out of the *Cathode outlet duct (7)* and purge tubing. Ensure that water does not drip to any electrical components. **Caution: there might be unreacted Hydrogen gas coming out of the purge tubing. Keep away from fire and electric spark. Ensure sufficient ventilation.**

3.4 SHUTTING DOWN PROTIIUM-2500

1. Turn OFF your load. The cooling fans will turn faster to cool down the fuel cell, before returning to their minimum speed.
2. In the GUI, click END. Alternatively, press and hold the On/Off push button (28) for more than 2s. The message <Shutdown Initiated> will appear in the GUI and PROTIIUM-2500 will enter its Shutdown Phase by carrying out a series of shutdown procedures such as turning off the gas supply valves, cooling fans and oxidant blowers.
3. The message <System OFF> will appear in the GUI. PROTIIUM-2500 is now turned off. Status LED will blink at 60% on standby awaiting the next start-up command.
4. If you do not intend to restart the system soon, turn OFF your Hydrogen gas supply and remove the Hydrogen gas tubing from the *H₂ gas inlet connectors (10 and 15)*. **Caution: some remaining gas in the tubing will be released into the atmosphere.**
5. Turn OFF the external power supply. All the cables can now be disconnected.

PROTIIUM-2500 is now ready to be kept for storage.

4 SYSTEM MONITORING, PROTECTIONS & MANUAL CONTROL

4.1 MANUALLY CONTROLLING THE PROTIUM-2500

The PROTIUM-2500 comes with in-built firmware control that is optimized to bring out its best performance over the applicable ambient environment range. In normal use-case scenario, there is no need for user to fine-tune the parameters. For advanced user who wishes to control the fuel cell manually, the following commands can be entered via the GUI:

Command	PROTIUM-2500 action
start <enter>	Starts the system
end <enter>	Enters normal shutdown phase
ver <enter>	Displays the firmware version
f <enter>	Return to automatic cooling fan control
b <enter>	Return to automatic oxidant blower control
p <enter>	Open the Hydrogen purge valve for 2s. This is useful to remove excess water if cell flooding is suspected due to decreasing power output.
= [equal]	Increase cooling fan speed by 5% [manual control]
- [hyphen]	Decrease cooling fan speed by 5% [manual control]
0	Increase cooling fan speed by 1% [manual control]
9	Decrease cooling fan speed by 1% [manual control]
]	Increase oxidant blower speed by 3% [manual control]
[Decrease oxidant blower speed by 3% [manual control]

Tip: you may also long press the *ON/OFF push button* by >2s to turn ON/OFF the system instead of entering “start” and “end” command via the GUI.

4.2 SYSTEM WARNING & PROTECTIONS

PROTIUM-2500 has several in-built protections. The LED will flash and error message will appear in the GUI. Follow the basic troubleshooting guide below. Most errors should be rectified once the suggested corrective action has been done and the system restarted.

If the error persists, contact support@spectronik.com.

4.2 SYSTEM WARNING & PROTECTIONS (Cont.)

Warning messages during “Starting Phase”:

Message	Meaning/ Corrective Action
"Gas Tank Not Detected"*	Either the gas tank communication cable is not connected or the tank is empty.
"Gas Tank Pressure Low" *	There is less than 20 Bar remaining in the gas tank.
"Gas Tank Insufficient Pressure" * ●	There is not enough pressure in the gas tank to start.
"Error: Gas Tank at High Temperature" * ●	The Gas Tank internal temperature is above 60°C. Please check for abnormalities.
"Low H2 Supply"	Hydrogen supply pressure is low and the system will wait up to 1min for correction. Please check and correct the delivery pressure.
"Error: Low H2 Supply" ●	Hydrogen is not correctly supplied within the stipulated time limit. Check and ensure sufficient Hydrogen supply and correct delivery pressure. Restart the system.
"Over Pressure"	Hydrogen supply pressure is too high and the system will wait for 1min. Reduce the delivery pressure.
"Error: Over Pressure" ●	Hydrogen is not properly supplied within the stipulated time limit. Check and ensure sufficient Hydrogen supply and correct delivery pressure. Restart the system.
"High Temperature"	Stack temperature is too high and the system will wait for 1min.
"Error: High Temperature" ●	Disconnect everything and wait for system to cool down and restart after 10min. If the problem persists, internal temperature sensor might have been compromised. Contact Spectronik.
"Error: FC Over Cooled" ●	Stack temperature is too low. Wait for ambient temperature to increase and restart the system.
"FC Sealing Compromised" ●	Possible stack leakage. Check and ensure all gas tubing and connectors are securely connected.
"Error: Low Voltage" ●	Stack open circuit voltage is too low. Check and ensure sufficient hydrogen supply and correct delivery pressure. Restart after 1 min.

● *Emergency Shutdown = "Abnormal Shutdown" would be activated*

* *with purchase of optional Spectronik accessories (gas tank and pressure regulator)*

4.2 SYSTEM WARNING & PROTECTIONS (Cont.)

Warning messages during “Running Phase”:

Message	Meaning/ Corrective Action
"High Temperature" ●	Stack temperature is too high. The fuel cell power output to load will be temporarily disconnected for 5s for system to recover. LED will blink. Reduce your load.
"Error: High Temperature" ●◎	Stack temperature is too high. Disconnect everything and wait for system to cool down and restart after 10min. If the problem persists, internal temperature sensor might have been compromised. Contact Spectronik.
"Low Temperature" ●	Stack temperature is low. LED will blink.
"Error: FC Over Cooled" ◎	Stack temperature is too low for operation.
"Low Voltage" ●	Stack Voltage at minimum threshold of 0.6V/cell.
"Error: Low Voltage" ◎	Stack Voltage below safety threshold limit.
"Low H2 Supply" ●	Hydrogen supply pressure is low and the fuel cell power output to load will be temporarily disconnected. LED will blink. Check and ensure sufficient Hydrogen supply and correct delivery pressure.
"Error: Low H2 Supply" ◎	Hydrogen supply pressure is too low. Check and ensure sufficient Hydrogen supply and correct delivery pressure. Restart the system.
"High H2 Supply Pressure" ●	Hydrogen supply pressure is too high and the supply valve will be temporarily shut off. LED will blink at 80%. Reduce the delivery pressure.
"Error: High H2 Supply Pressure" ◎◎	Hydrogen supply pressure is too high. Check and ensure sufficient Hydrogen supply and correct delivery pressure. Restart the system.
"Low Battery" ●	The External Power Supply is at below 15V.
"Gas Tank Running Low" *●	The pressure in the gas tank is below 20 Bar.
"Gas Tank Depleting" *●	The pressure in the gas tank is below 10 Bar.
"Error: Gas Tank at High Temperature" *◎	The Gas Tank internal temperature is above 60°C. Please check for abnormalities.

◎ *Emergency Shutdown = "Abnormal Shutdown" would be activated*

● *LED flashing at 80% to alert warning in the running*

* *with purchase of optional Spectronik accessories (gas tank and pressure regulator)*

4.2 SYSTEM WARNING & PROTECTIONS (Cont.)

Other messages:

Message	Meaning
Fan PWM auto	Cooling fans control is in auto mode
Blower auto	Oxidant blower control is in auto mode
Mileage	Cumulative Watt-Hour of the system
Shutdown initiated	Entering "Normal Shutdown Phase"
Abnormal Shutdown initiated	Entering "Abnormal Shutdown Phase" due to an error
System off	System is turned off and ready to restart at the next command

LED status:

Phase	Blink % (at 1Hz)	Meaning
Power ON	10%	5s after start-up power is provided into the fuel cell controller, LED will blink at 10%, indicating that the system is ready to receive its "start" command
Starting Phase	40%	Executing "Starting Phase" procedures
Running Phase	100%	System in normal "Running Phase"
Running Phase	80%	System warning during "Running Phase"
After shutdown	60%	System off due to normal shutdown and on standby for the next "start" command
After shutdown	0%	System off due to abnormal shutdown

5 MAINTENANCE AND STORAGE

5.1 MAINTENANCE FOR PROTIUM-2500

When not in use, Spectronik recommends that PROTIUM-2500 is reconditioned at least once a month.

1. Set up PROTIUM-2500 as per instructions in Section 3, using a DC electronic load in lieu of your regular load.
2. After the system enters "Running Phase", set constant voltage (CV) load of 50V and run the system for 1h. The fuel cell should recover to its maximum rated power output.

PROTIUM-2500 is now ready for usual operation or can be stored again for future use.

5.2 STORAGE

Keep PROTIUM-2500 in an open, cool (standard room temperature of 25°C) and dry place.