

S SPECTRONIK

PROTIUM-25

FUEL CELL SYSTEM

USER GUIDE



SAFETY, HANDLING & SUPPORT

WARNING:

Failure to follow these safety instructions could result in fire, electric shock, or other injuries, or damage to PROTIUM-25 Fuel Cell System (PROTIUM-25) or other property. Read all the safety information below before using PROTIUM-25.

Handling Handle PROTIUM-25 with care. It is made of thin sheet metal, graphite, and plastic and has sensitive electrochemical membrane and components inside. PROTIUM-25 is not designed for extreme conditions, rough handling, vibration, shock or drop. Keep PROTIUM-25 away from heat, flame, strong sunlight, water, dust, soil or mud. Do not use a damaged PROTIUM-25.

Repairing Do not troubleshoot, disassemble or tamper with PROTIUM-25. Do not attempt to repair or replace any component by yourself.

Hydrogen Use only high purity (99.999%) dry Hydrogen gas with PROTIUM-25. Follow all local rules and regulations for safe handling, storage and usage of Hydrogen gas. Do not smoke when operating PROTIUM-25.

Purging and ventilation Operate PROTIUM-25 in a well ventilated environment. Fresh air intake for the fuel cell stack and exhaust from its purge valve shall not be obstructed or restricted. PROTIUM-25 periodically flushes its anode during operation, releasing Hydrogen gas and water from the purge valve.

CAUTION: always put the purge valve outlet behind the cooling fan and never in front of the fuel cell stack. Purged Hydrogen mixed with air intake into the fuel cell's cathode channels may cause fire and irreversible damage to the fuel cell. It is advisable to attach a longer gas tubing to the purge valve's outlet and safely guide the purge exhaust far away from the fuel cell.

Connectors, ports and buttons Never force a connector into a port or apply excessive pressure to a button. If the connector and port do not join with reasonable ease, they probably do not match. Check for obstructions and ensure that the connector matches the correct port.

Disposal and recycling As PROTIUM-25 contains electronic components and batteries, it must be disposed of separately from household waste. When PROTIUM-25 reaches its end of life, follow local laws and regulations for proper disposal and recycling options.

High-consequence activities PROTIUM-25 is a customized system with pending safety tests and certifications. It is not intended for use where the failure of the system could lead to death, personal injury or severe environmental damage.

Disclaimer Every effort has been made to ensure that the information in this manual is accurate. This manual serves to adequately recommend safe operating procedures, but shall not be treated as comprehensive. Do not use PROTIUM-25 in any other way than the one recommended in this manual. Spectronik reserves the right to change system specifications, appearance or discontinue the product at any time.

Warranty Spectronik warrants the included hardware product and accessories against defects in materials and workmanship for the first 30 days after delivery. Spectronik does not warrant against normal wear and tear, nor damage caused by accident or abuse.

To obtain service, contact support@spectronik.com

1 OVERVIEW

WHAT'S IN THE BOX

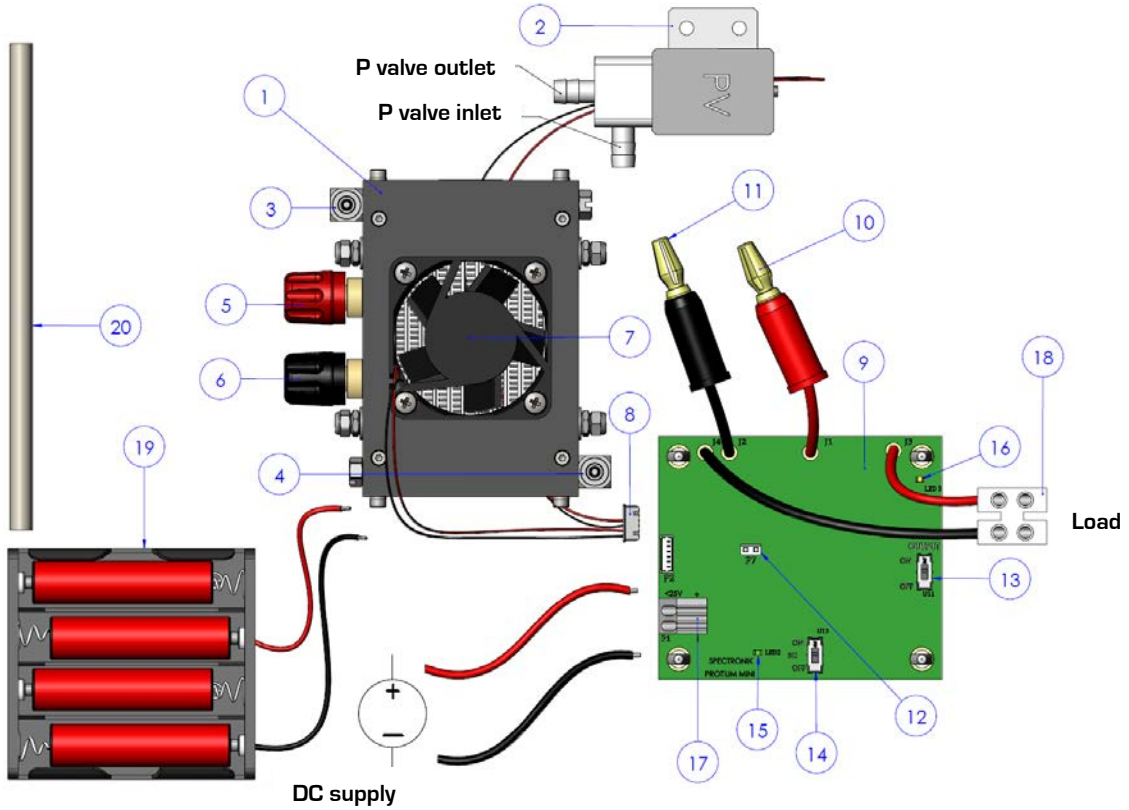

ITEM DESCRIPTION

1.	PROTIUM-25 fuel cell stack	11.	Stack output connector plug [-ve]
2.	Purge valve	12.	Jumper removable switch
3.	H ₂ gas inlet connector	13.	Load power output toggle switch
4.	H ₂ gas outlet connector	14.	Stack short-circuit toggle switch
5.	Stack output connector receptacle [+ve]	15.	LED2
6.	Stack output connector receptacle [-ve]	16.	LED3
7.	Cooling fan	17.	Auxiliary power input P1 connector
8.	P2 connector (to electronic controller)	18.	Load power output connector
9.	Electronic controller	19.	Auxiliary 4xAA battery holder
10.	Stack output connector plug [+ve]	20.	Silicon purge tubing

Note: AA battery not included

2 SPECIFICATIONS

2.1 DATA SHEET

Fuel Cell System	
Type	PEM, 10cells, Open-cathode
Rated/Gross Power	25/30W
Rated/Gross Current	4.2/5A
Voltage Output	6-9V
Start-up Time	5s
Fuel Cell Max Dimension	93 x 78 x 87 mm
Fuel Cell Weight	360g
Operating Ambient Temperature	(0,40)°C
Operating Altitude	1500m AGL
Efficiency	48% (based on LHV of H ₂)
Fuel Supply	
Hydrogen Gas	Dry, 99.999% purity
Delivery Pressure	0.3-0.35barg (4-5psig)
Max Consumption	0.3L/min @ 25W
Gas Tubing Requirement	Silicon, ID 4mm
Automated Periodic Purge	5V electro-valve
Electronic Controller	
Processor Board	Mini V1.0
PCBA Dimension	70 x 60 x 30 mm
PCBA Weight	56g
Output Connector (stack)	Banana test connector, 4mm, receptacle and plug, 35A 60V
Output Connector (load)	Terminal block, 20A, 12-22AWG
External Power Requirement	5V, 0.5A
System Monitoring & Protections	
Error 1 (E1)	Low voltage during starting phase
Error 2 (E2)	Low voltage during running phase
Error 3 (E3)	Persistent E2, system shutdown
Graphic User Interface	Android App
Communication	Bluetooth 4.0
Data Acquisition	Live data logging into CSV file
Possible User Configuration	
Configuration #1	With DC start-up power supply
Configuration #2	With auxiliary start-up battery
Configuration #3	Externally powered balance-of-plant
Configuration #4	Hybrid battery for increased load output power

2.2 MECHANICAL DIMENSIONS

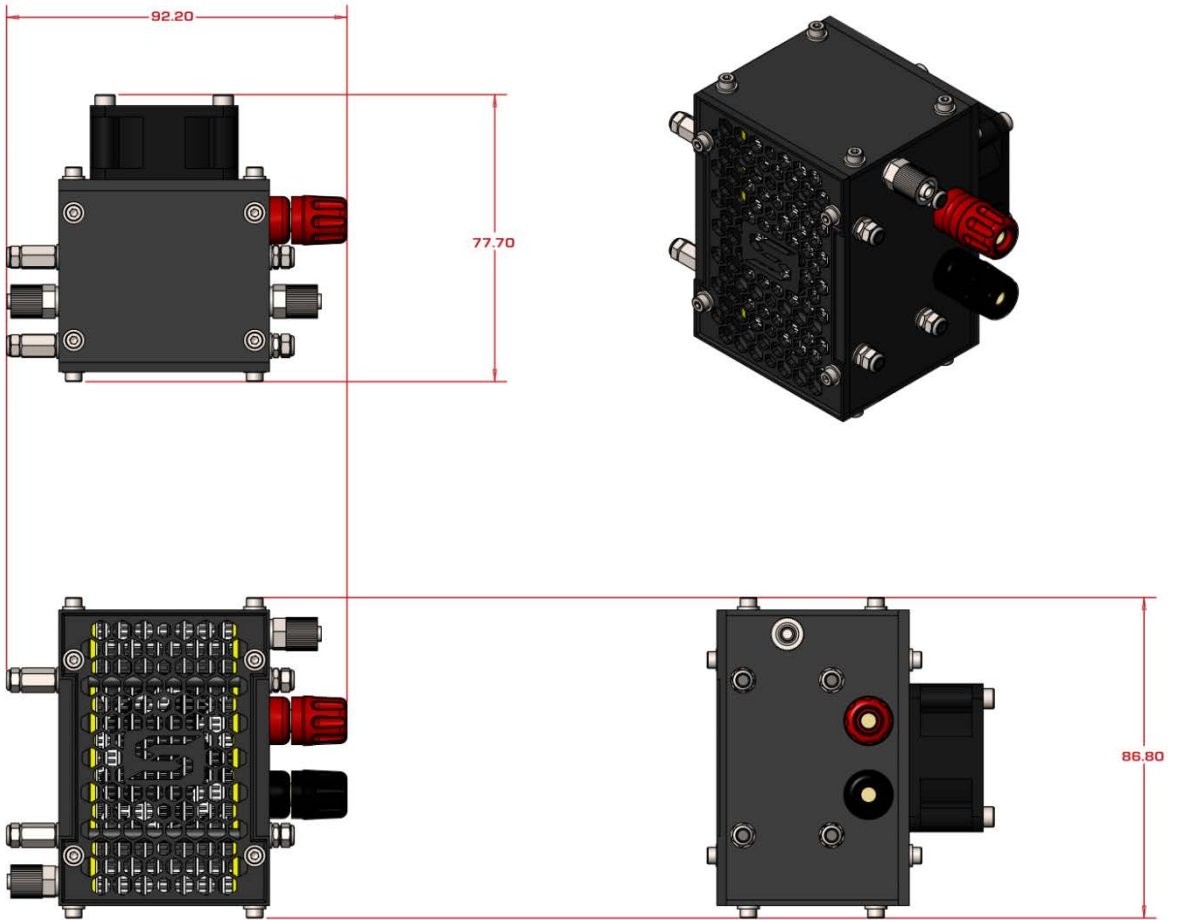

2.3 VI CURVE

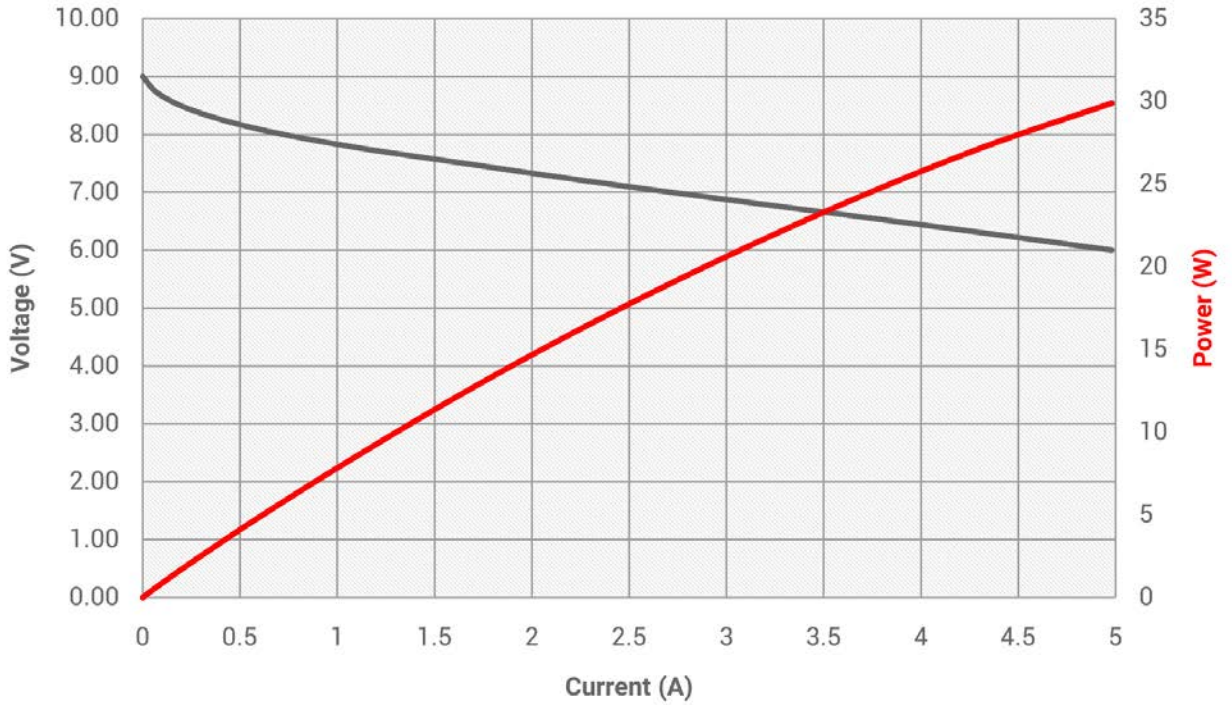

Test Conditions

- Ambient temperature: 24°C
- Relative humidity: 60%
- H₂ supply pressure: 5psig
- Dead-ended operation
- Balance-of-plant powered by external supply
- T_{cell} at 25W: 54°C

3 OPERATING PROCEDURES

SETTING UP PROTIUM-25

PROTIUM-25 has 4 different user configurations depending on the application objective.

Configuration #1 (with DC start-up power supply)

In Configuration #1, an adjustable DC power supply is required for the initial start-up of the electronic controller. This configuration is suitable for lab bench-top experiments.

1. Connect purge tubing (20) between the inlet of the purge valve (2) and H₂ gas outlet connector (4).

Caution: always put the purge valve outlet behind the cooling fan and never in front of the fuel cell stack.

2. Connect P2 receptacle (8) into its respective header on the electronic controller (9). **Tip:** for safety, ensure that all switches (13) and (14) is OFF at this stage.
3. Ensure that jumper (12) is in place.
4. Plug (10) and (11) to (5) and (6) respectively.
5. Connect your load into (18). **Tip:** check that the polarity is correct. It is also advisable to put an ON/OFF switch at your load and ensure that it is turned OFF at this time.
6. Using a DC power supply, provide a 5-5.8V, 0.5A input to Auxiliary power input P1 (17). LED2 (15) will light up and cooling fan (7) will start to spin.
7. Supply Hydrogen gas regulated to 5psig pressure into (3). PROTIUM-25 is now live.
8. Toggle (13) to ON. Gas purging sound can be heard and LED3 (16) will light up. The fuel cell will begin delivering power to (18). Turn ON your load to draw power.

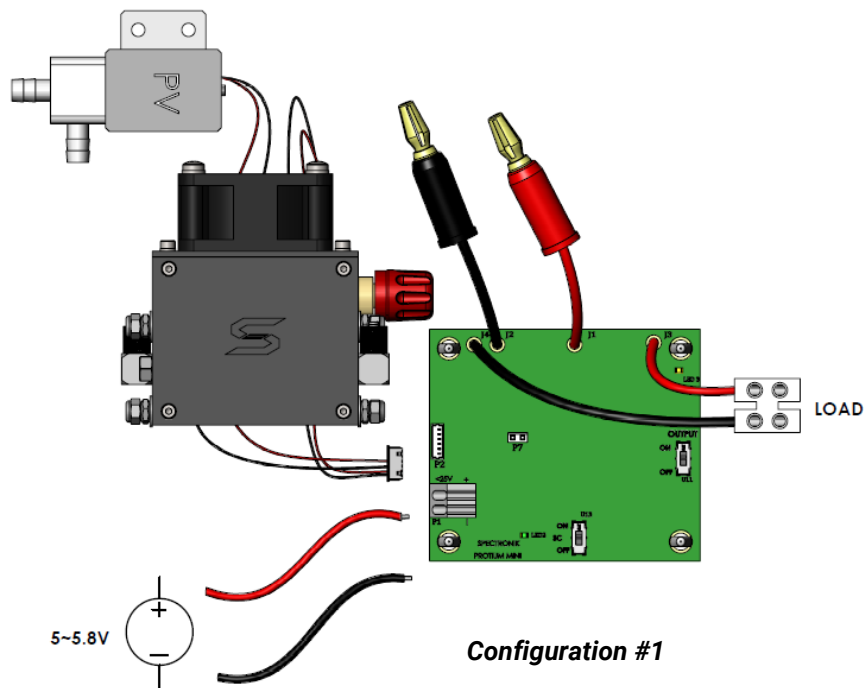

Configuration #2 (with auxiliary start-up battery)

In Configuration #2, an auxiliary battery is used for the initial start-up of the electronic controller. This configuration is suitable for mobile/portable application.

- Fill auxiliary battery holder [19] with 4x AA battery.
- Repeat the procedures in Configuration #1, replacing the DC power supply in step 6 with the auxiliary start-up battery.

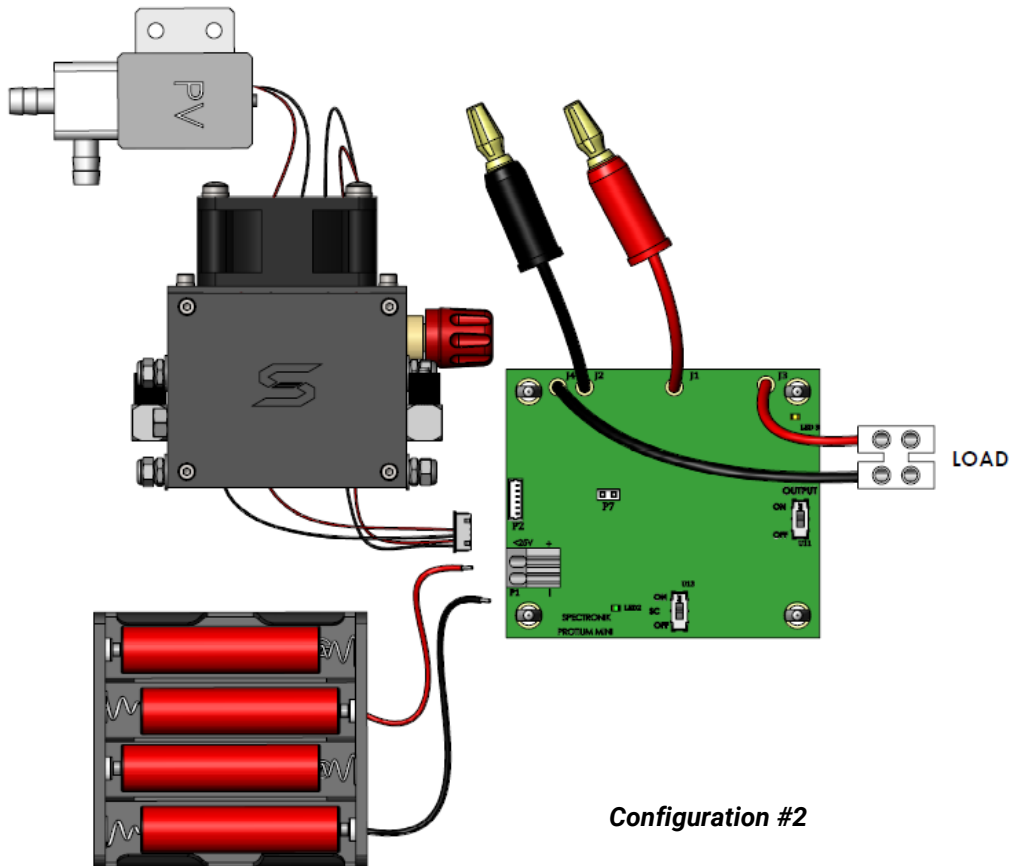

Configuration #4 (Hybrid battery for increased load output power)

In Configuration #4, a hybrid battery is added in parallel to PROTIUM-25 at the load output. This configuration is suitable when more power beyond the fuel cell's rated output is desired.

Caution: Never connect the load output of PROTIUM-25 directly to a battery without electrical protection such as a diode in place.

- Follow steps 1-5 of Configuration #3.
6. Connect your load and hybrid battery with diode into (18). **Tip:** check that the polarity is correct. It is also advisable to have an ON/OFF switch for the hybrid battery and that it is OFF at this stage.
 7. Turn ON the hybrid battery. LED2 (15) and LED3 (16) will light up.
 8. Supply Hydrogen gas regulated to 5psig pressure into (3). PROTIUM-25 is now live.
 9. Toggle (13) to ON. Gas purging sound can be heard. The fuel cell will begin delivering power to (18). Turn ON your load to draw power.

Tip: it is also possible to connect a DC power supply in lieu of the hybrid battery.

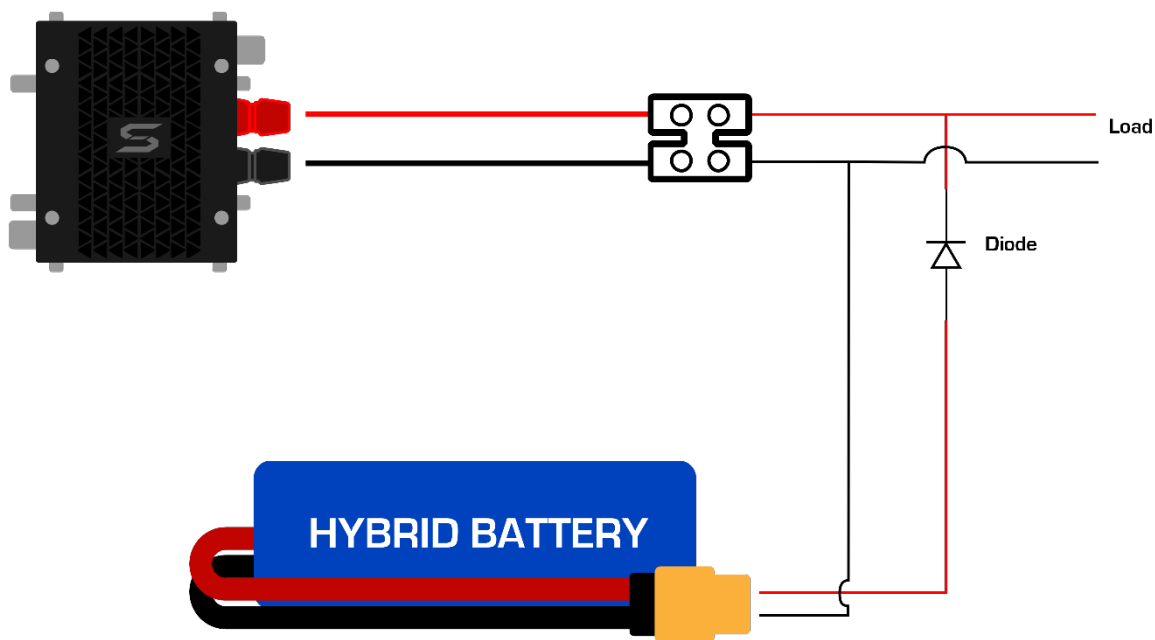

Configuration #4

NOTES

- **Purging and ventilation** Operate PROTIUM-25 in a well ventilated environment. Fresh air intake for the fuel cell stack and exhaust from its purge valve shall not be obstructed or restricted. PROTIUM-25 periodically flushes its anode during operation, releasing Hydrogen gas and water from the purge valve. Do not bring flame or electric spark close to the purge valve's outlet.

Caution: always put the purge valve outlet behind the cooling fan and never in front of the fuel cell stack. Purged Hydrogen mixed with air intake into the fuel cell's cathode channels may cause fire and irreversible damage to the fuel cell. It is advisable to attach a longer gas tubing to the purge valve's outlet and safely guide the purge exhaust far away from the fuel cell.

- **Short-Circuit (SC):** during normal operation, PROTIUM-25 output power will decay after some time. This is normal. **To rejuvenate the stack and maintain high power output, toggle the SC (14) to ON.** Note that the load will temporarily lose power (100ms duration every 15s period) when SC is ON.

- **Over-power:** do not draw power in excess of the fuel cell's rated power (25W). If hybrid battery is connected, PROTIUM-25 will provide its maximum output while the rest is augmented by the battery. The total power available depends on the capacity of the battery.

- **Voltage balancing with hybrid battery:** in Configuration #4, the load will predominantly take power from the higher voltage source. To maximize the fuel cell power output, it is advisable to match the hybrid battery's voltage at around 6V.

- **Supply valve:** while not necessary, it is advisable to install a valve at the Hydrogen supply line for ease of cutting off the gas supply during shutdown or in case of emergency.

REMINDERS

- Ensure all gas tubing and electrical wire connections are firm and secure.

- Check the delivery pressure of the hydrogen gas supply. Insufficient pressure will affect PROTIUM-25's performance while excessive pressure might rupture its membrane electrode assembly and cause permanent damage.

Shutting down PROTIUM-25

At the end of your operation:

1. Turn OFF your load at (18).
2. Toggle the switches (13) and (14) to OFF.
3. Shut off the Hydrogen supply into gas inlet connector (3).
4. Stop or disconnect the input power supply at (17).
5. Disconnect all cable, wiring and gas tubing.

4 SYSTEM MONITORING & PROTECTIONS

During operation, you can view PROTIUM-25 system parameters live via an Android app:

1. Download the Graphic User Interface (GUI) app online:
<https://www.spectronik.com/protium-25>
2. Install the app on your android device. Turn on Bluetooth and allow the app to access photos and medias on your device as well as the device's location.
3. Click 'Scan' to find PROTIUM-25. It will appear in its product ID. **Tip:** the product ID can be found on the label pasted on the fuel cell and its storage box.
4. Once the system is connected, you can view the fuel cell's Voltage, Current, Power and Energy values in real time.
5. To log the data in csv format, tap on the 'Data Logging' button at the bottom of the screen. The app will start recording the live system parameters.
6. To access the file, tap on the three buttons icon on the top right side of the screen and choose 'Open file'. You can also find the file in the following directory: File manager/MyFiles > Internal storage > Android > data > com.spectronik.GUI > files > miniDataLog.csv

Tip: the app cannot run in the background. If you leave the screen, or access the data log file while the system is still running, it will not record the latest data. Once you return to the app, it will continue to append new rows of data to the file.

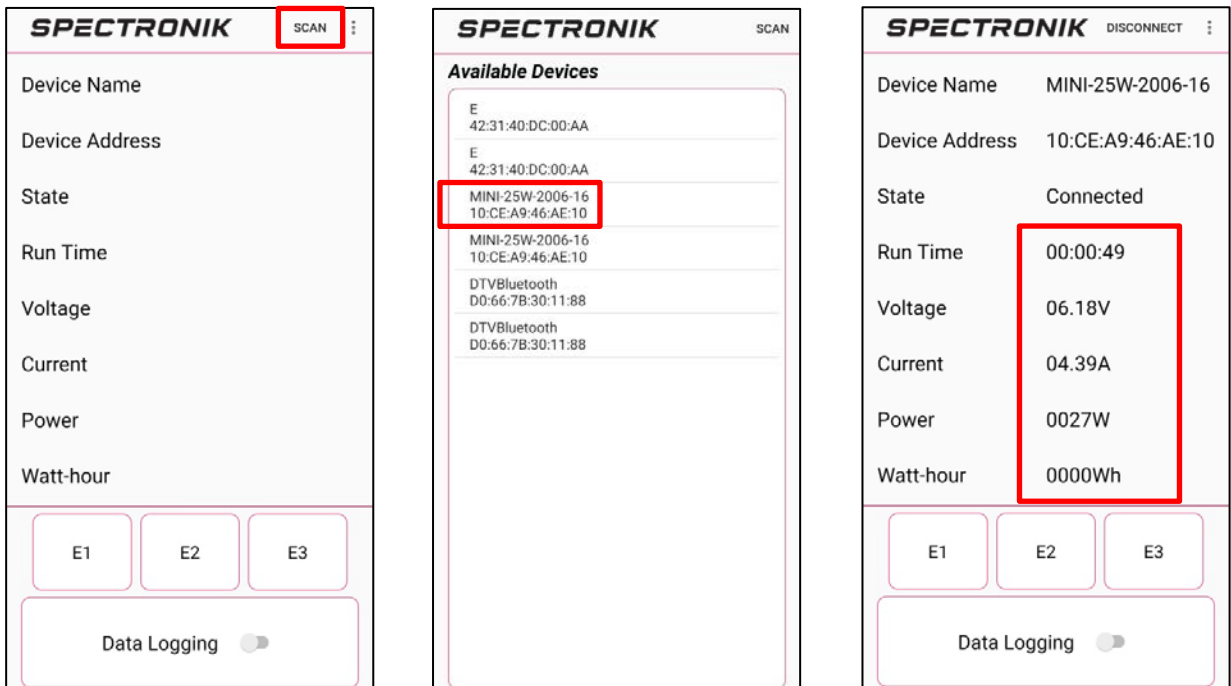

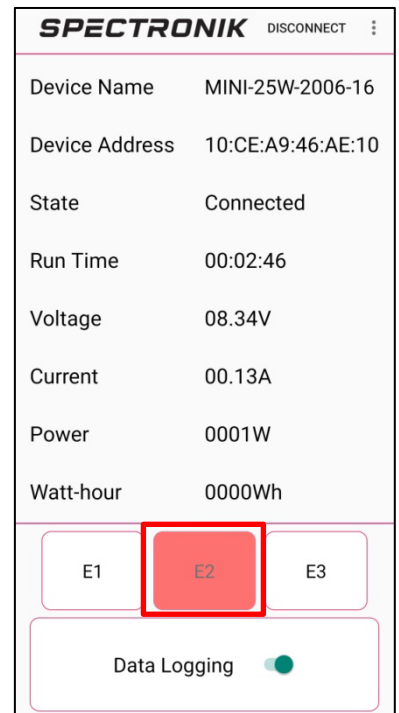
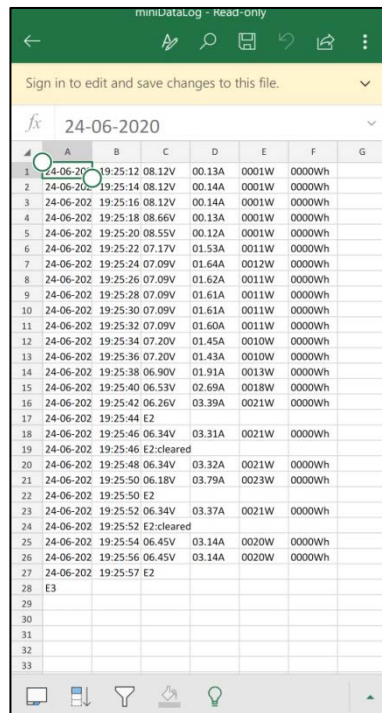
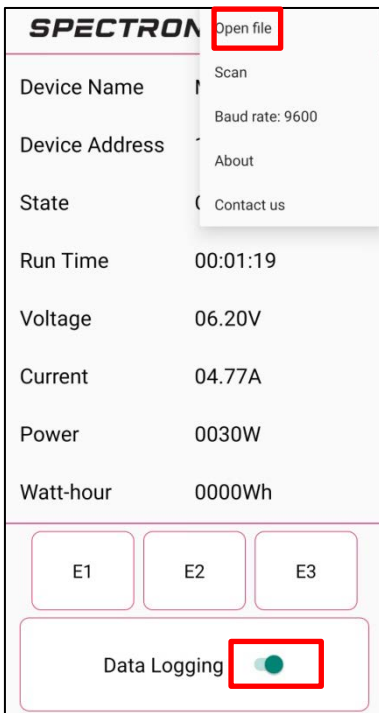

PROTIUM-25 has several in-built protections. A red light will flash in the 'E1', 'E2' or 'E3' box on the app, depending on the type of error that occurs. Follow the basic troubleshooting guide below. Most errors should be rectified once the suggested action has been done and the system restarted. If the error persists, contact support@spectronik.com.

Error	Corrective Action
E1	<p>E1 = low stack voltage during starting phase.</p> <ul style="list-style-type: none"> • Ensure sufficient Hydrogen supply and correct delivery pressure. • Ensure that plugs (10) and (11) are securely connected into the receptacles (5) and (6). • Ensure all gas tubing and connectors (3) and (4) are not loose. <p>Caution: if audible gas hissing sound can be heard, the stack sealing may have been compromised. Turn off the Hydrogen gas supply and stop all operations. Contact Spectronik.</p>
E2	<p>E2 = low stack voltage during normal running phase. The electronic controller will cut off the power output to load, LED3 (16) will turn OFF. If the stack voltage recovers, the power output to load will automatically re-engage and LED3 (16) will turn ON again. Otherwise, the system will shutdown.</p> <ul style="list-style-type: none"> • Ensure sufficient Hydrogen supply and correct delivery pressure. • Reduce your load, make sure not to draw more than the fuel cell's rated power output.
E3	<p>E3 = automatic system shutdown as a protection due to consecutive E2 errors.</p> <ul style="list-style-type: none"> • Ensure sufficient Hydrogen supply and correct delivery pressure. • Reduce your load, make sure not to draw more than the fuel cell's rated power output. • Check the entire set-up and attempt a restart after a few minutes.

5 MAINTENANCE AND STORAGE

MAINTENANCE FOR PROTIUM-25

When not in use, Spectronik recommends that PROTIUM-25 is reconditioned at least once a month.

1. Set up PROTIUM-25 in Configuration #3, using a DC electronic load in lieu of your regular load.
2. After the system is live, ensure that SC (14) is ON.
3. Set a constant voltage (CV) load of 6V and run the system for 1 hour. The fuel cell should recover to its maximum rated power output.
4. PROTIUM-25 is now ready for usual operation or can be stored again for future use.

STORAGE

Keep PROTIUM-25 in an open, cool (standard room temperature of 25°C) and dry place.